

FITTING INSTRUCTIONS AND DIAGRAM FOR WARRIOR SEQUENTIAL LED INDICATORS

CAUTION

Before fitting your LED indicators, please take the time to read through the fitting instructions and to study the diagram to ensure you understand how to mount and wire the indicators. If you are unsure in any way, please contact your local garage or dealer for help.

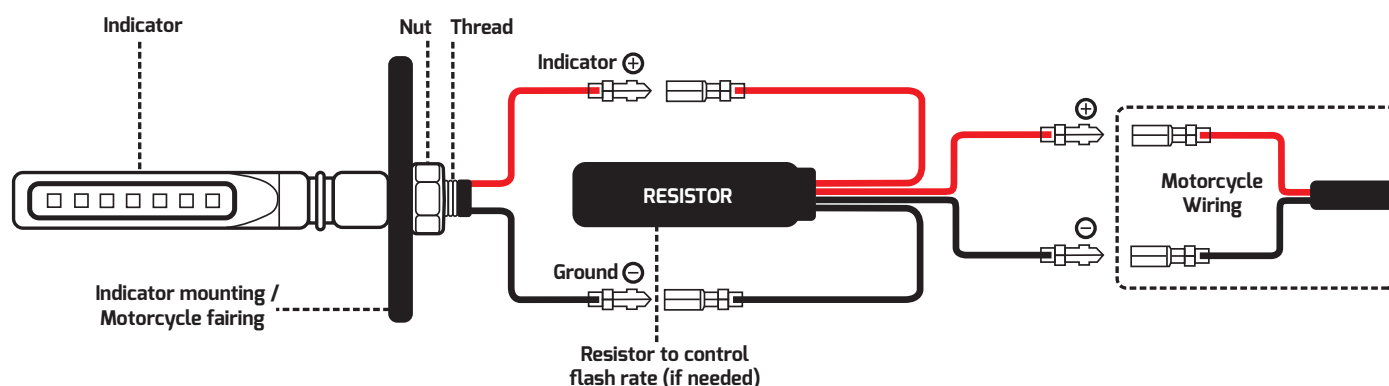

FITTING INSTRUCTIONS

1. Remove original indicators or drill holes if mounting in different place to OE indicators
2. Unscrew the nut from the rear of the indicator and pass over wires
3. Insert the LED indicators through the indicator mounting hole (Indicator spacers may be needed on some bikes).
4. Thread nut back over the indicator wires
5. Whilst holding the indicator in its desired position, re-tighten the nut (do not over tighten)
6. Wire the indicators as per the wiring diagram below.

The resistors supplied with the indicators are ideal most vehicles fitted with 21W indicator bulbs (although some models may require an extra resistor to give the proper flash rate). If you prefer to fit (or your bike is already fitted with) an LED indicator flasher relay, then the supplied resistors will not be required.

If used for extended periods (e.g. hazard lights), the resistors can get hot, so it is preferable to mount the resistors against a heat resistant surface, away from OE wiring looms.

Indicator adaptor leads are available separately for most motorcycles, should you not wish to modify the wiring on your motorcycle.