

TR80S Simulator

Assembly Guide

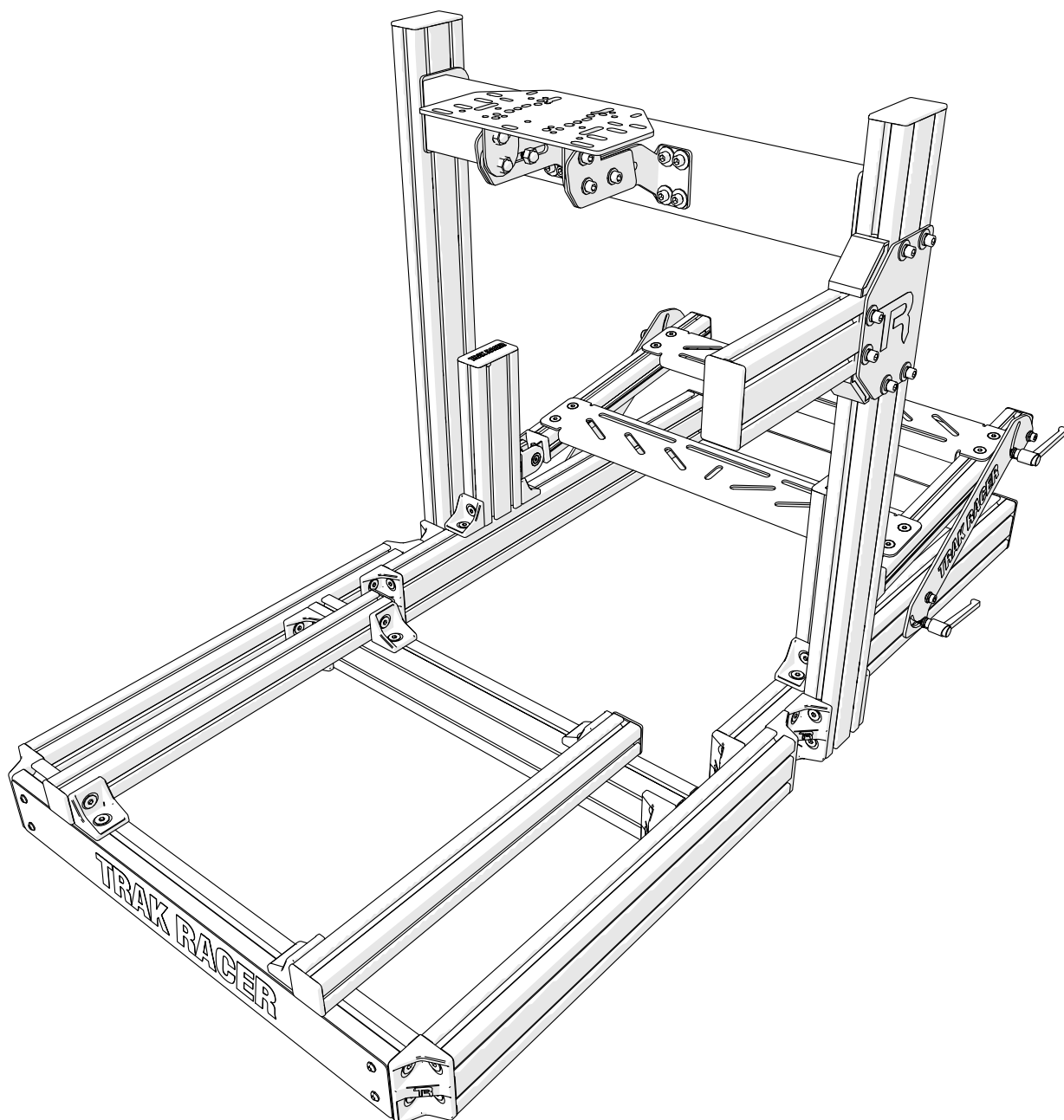

IMPORTANT: Different regions may have different models. Please ensure the part number below matches that on your product's box.

TR80S

TABLE OF CONTENTS

3 Symbol Legend

4 Part List

6 Assembly Notes

10 Assembly Instructions



IMPORTANT: Since there are different versions of each product based on your region, please make sure you are using the correct set of instructions. The part number below should match the one on your box.



IMPORTANT: Due to the nature of cut aluminum profiles, some metal shavings may remain despite our thorough QA cleaning process. We recommend opening boxes and packaging on a hard surface.



NOTE: Some screws and washers may be pre-installed. These are included in the parts list and will need to be loosened and reattached according to the instructions.



Recommended: Two people for the task



Tighten the hardware



Keep the hardware loose for adjustments

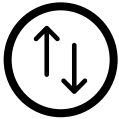

Make the necessary adjustments



Break the tab off the corner bracket



Safety glasses required



Attention/Priority needed



Reserve for the next step



Mirrored components (same on both sides)

PART LISTS

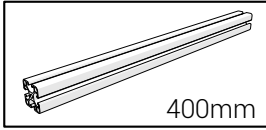

400mm

Aluminum Profile

TR-8040-400 x2

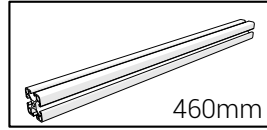

460mm

Aluminum Profile

TR-8040-460 x2

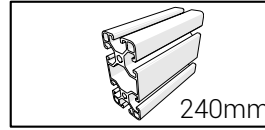

240mm

Aluminum Profile

TR-8080-240 x2

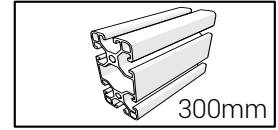

300mm

Aluminum Profile

TR-8080-300 x1

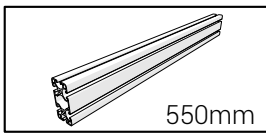

550mm

Aluminum Profile

TR-8080-550 x2

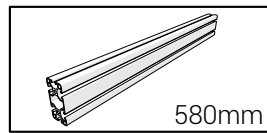

580mm

Aluminum Profile

TR-8080-580 x2

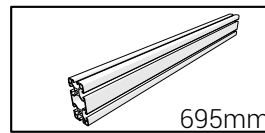

695mm

Aluminum Profile

TR-8080-695 x2

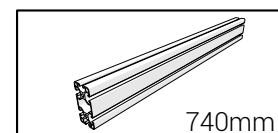

740mm

Aluminum Profile

TR-8080-740 x2

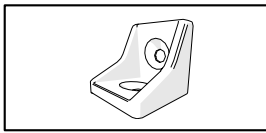

Corner Bracket, 40x40

CB-40 x8

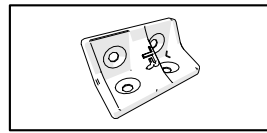

Corner Bracket, 40x80

CB-80 x12

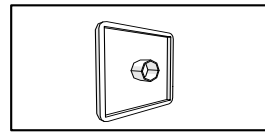

End Cap, 40x40

EC-40 x6

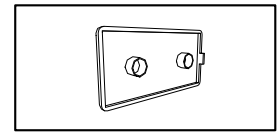

End Cap, 40x80

EC-80 x5

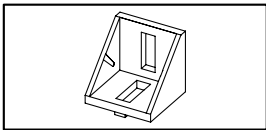

Corner Bracket

BC-40 x2

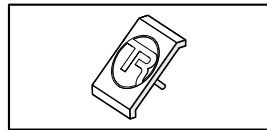

Corner Bracket with Cap

BC-40-CAP x2

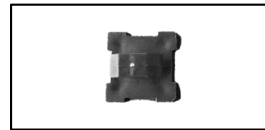

Cable Management Clip

CMC x6



Pedal Plate Side Mounts

PSM x2

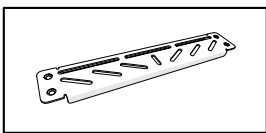

Pedal Plate

PP x2



Front Logo Plate

FLP x1



Rear Logo Plate

RLP x1

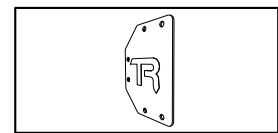

Shifter Side Plate

SFTSUP x1

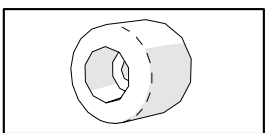

Rubber Feet

FR-01 x6

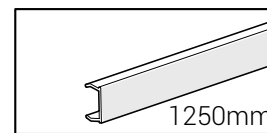

1250mm

Red Profile Strip

PS-1250-R x2

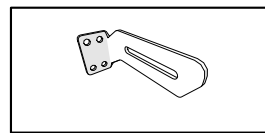

Wheel Mount 1

GRP1 x2

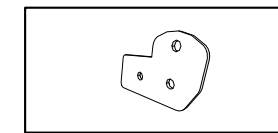

Wheel Mount 2

GRP2 x2

PART LISTS

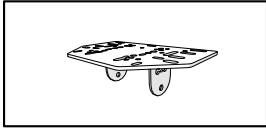

Wheel Mount 3

GRP3 **x1**

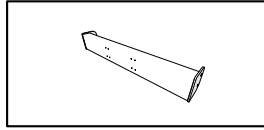

Wheel Mount 4

GRP4 **x1**

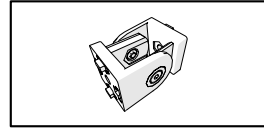

Adjustable Joint

AJ **x2**

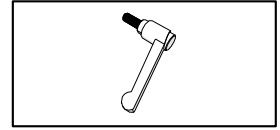

Lever Screw

LS **x4**

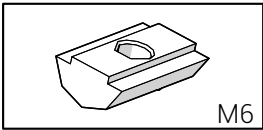

Ball Bearing Nut, M6

NS-M6 **x4**

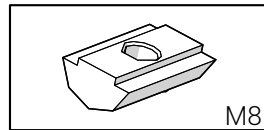

Ball Bearing Nut, M8

NS-M8 **x86**

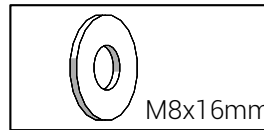

Washer (Flat)

WF-M8-16 **x14**

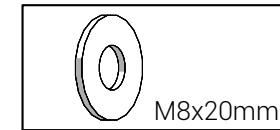

Washer (Flat)

WF-M8-20 **x28**

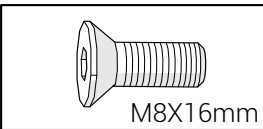

Screw (Flat)

SF-M8-16 **x56**

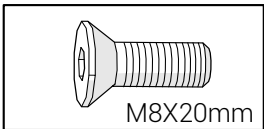

Screw (Flat)

SF-M8-20 **x12**

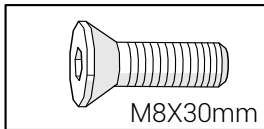

Screw (Flat)

SF-M8-30 **x8**

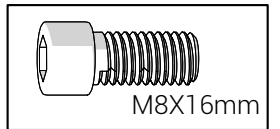

Hex Screw

SH-M8-16 **x12**

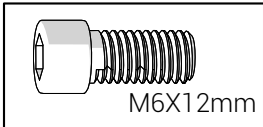

Hex Screw

SH-M6-12 **x4**

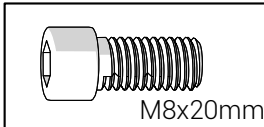

Hex Screw

SH-M8-20 **x30**

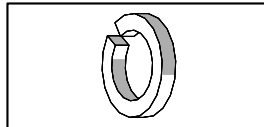

Washer (Lock), M8

WL-M8 **x22**

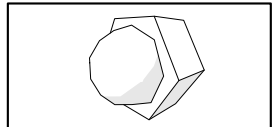

Cap Nut

NC-M8 **x6**

INCLUDED TOOLS

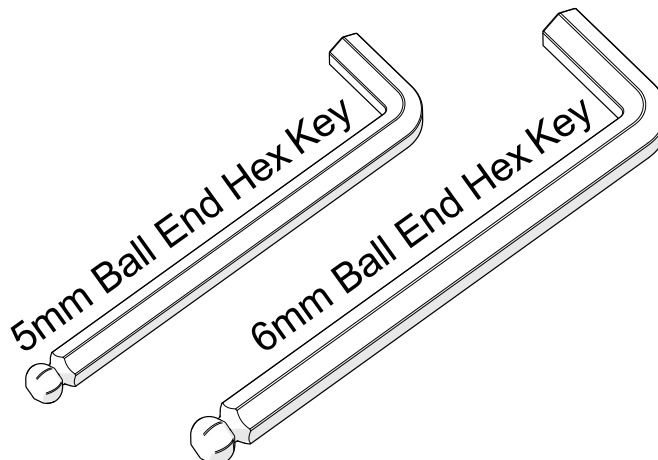

NOTE

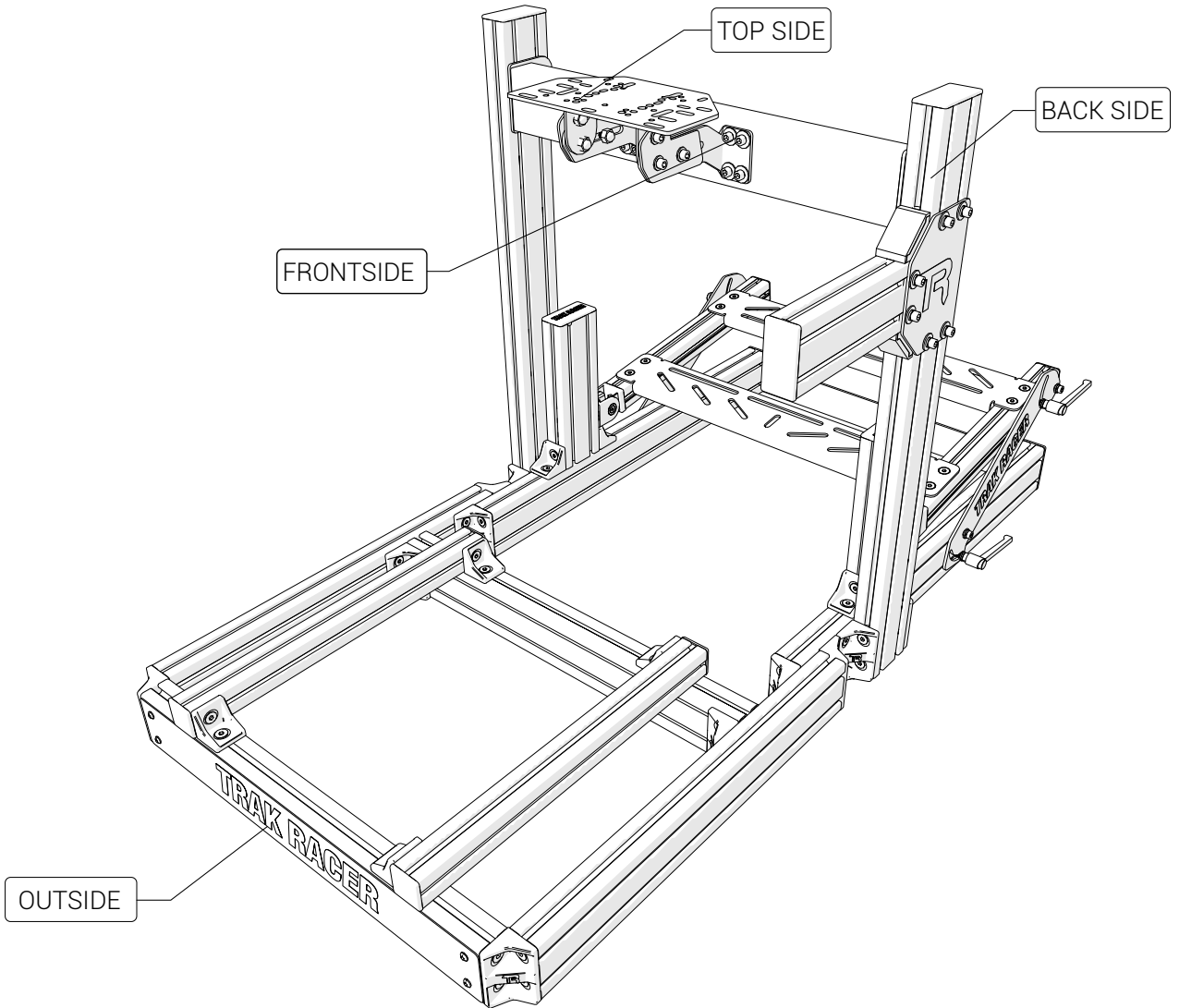

INSTALLATION ORDER FOR SCREWS & WASHERS

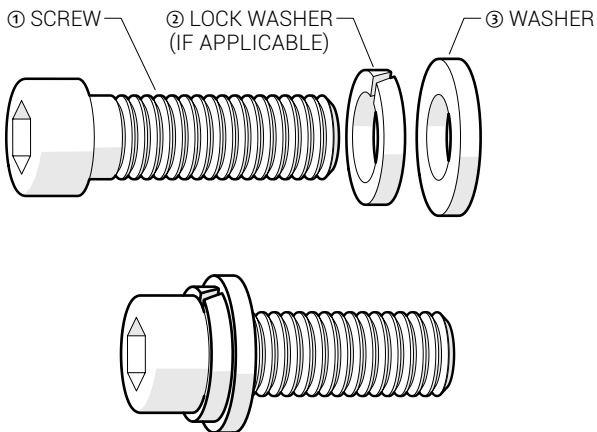

HOW TO MEASURE SCREWS

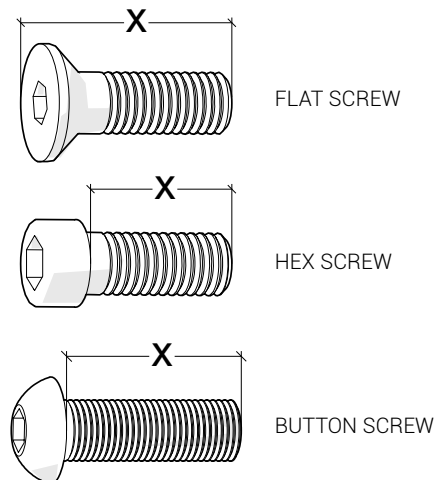

NOTE

The handle screws (S7 & S27) are ratcheted to allow for tightening and loosening when space for rotation is limited. Simply pull the handle out and turn handle into position and push handle back in to engage thread.

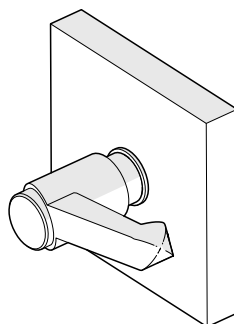
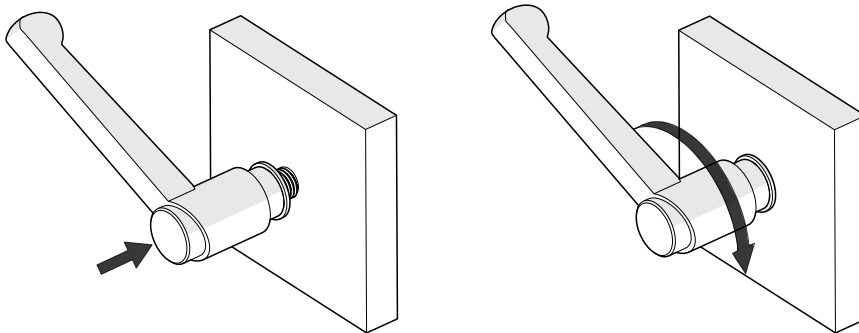
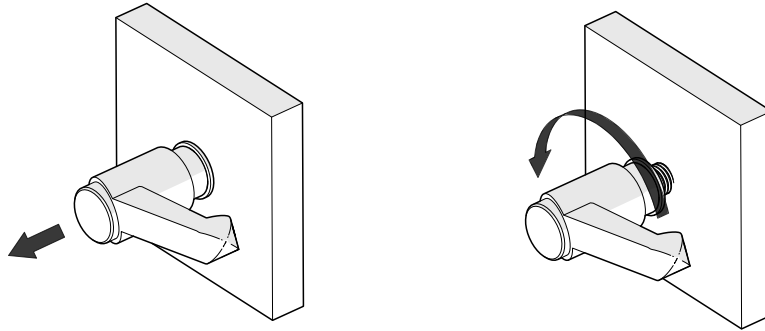
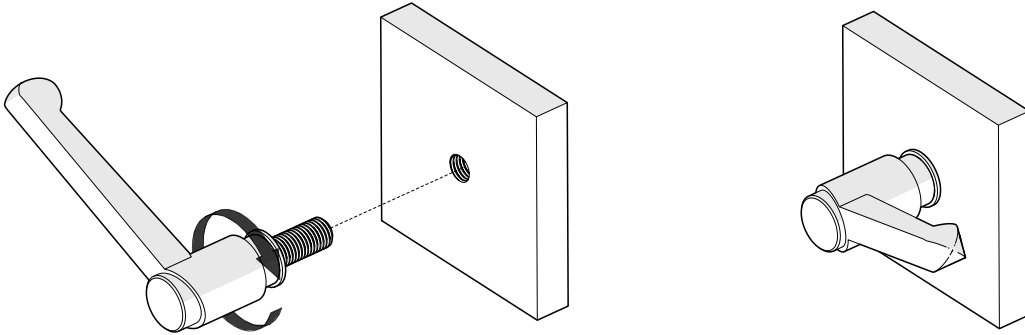

NOTE

BS-40

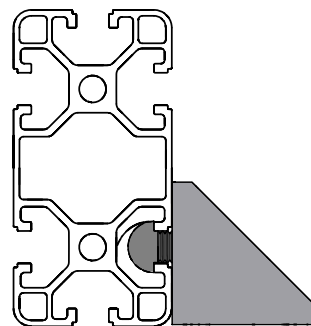
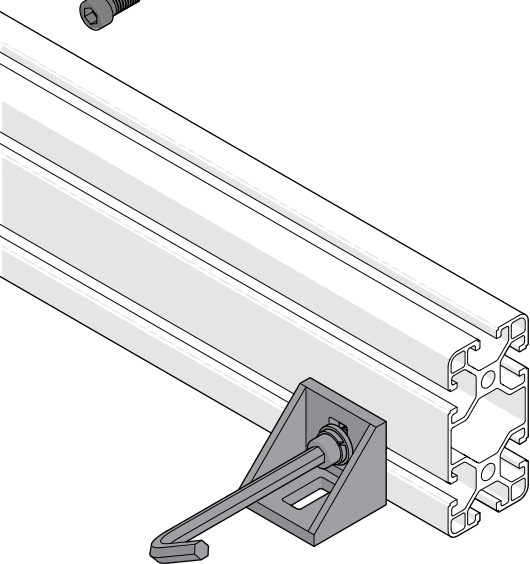
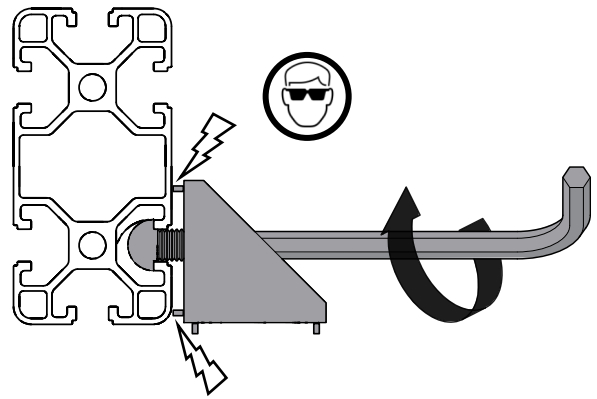
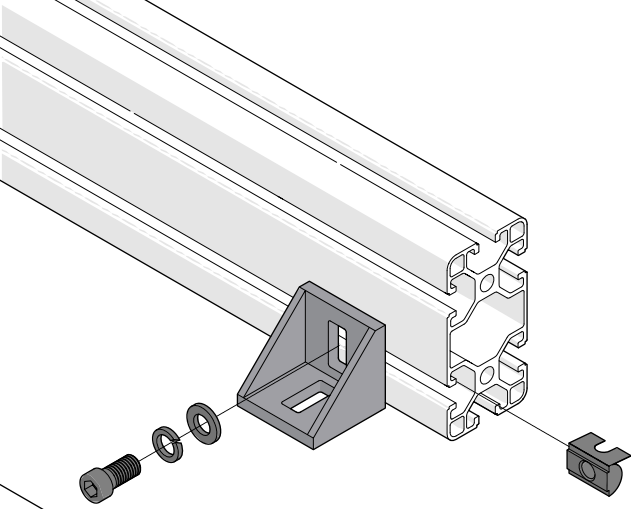
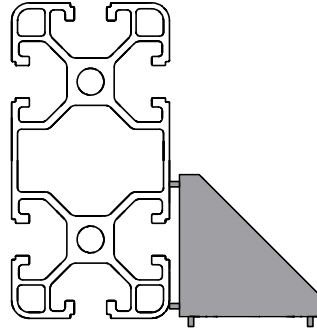
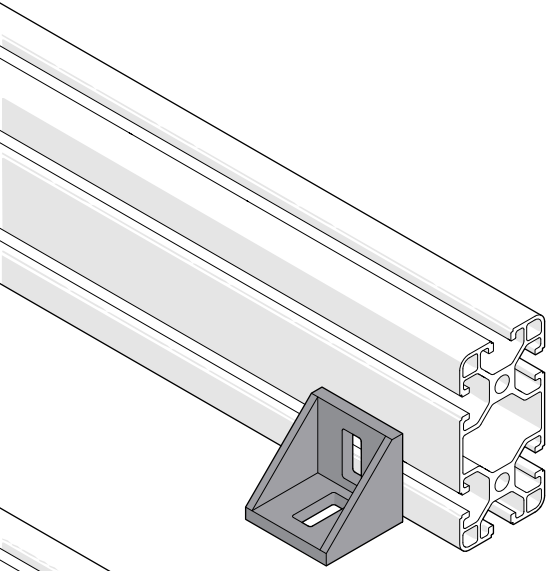

NOTE

NS-M8 & NS-M6

Slide T-Nuts into the ends of the profiles. Some must be added early, so follow the steps in this manual carefully.

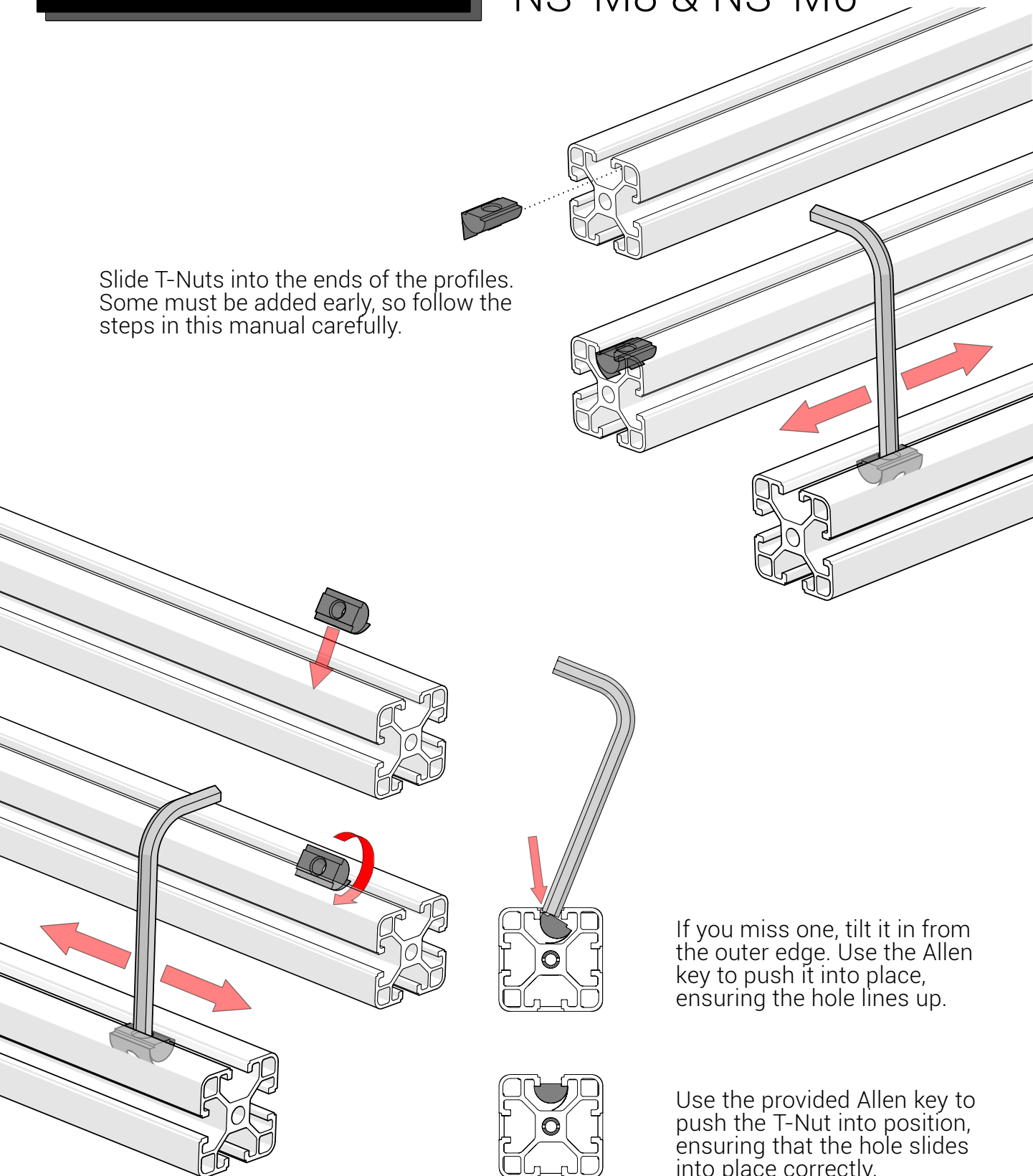

If you miss one, tilt it in from the outer edge. Use the Allen key to push it into place, ensuring the hole lines up.

Use the provided Allen key to push the T-Nut into position, ensuring that the hole slides into place correctly.

1

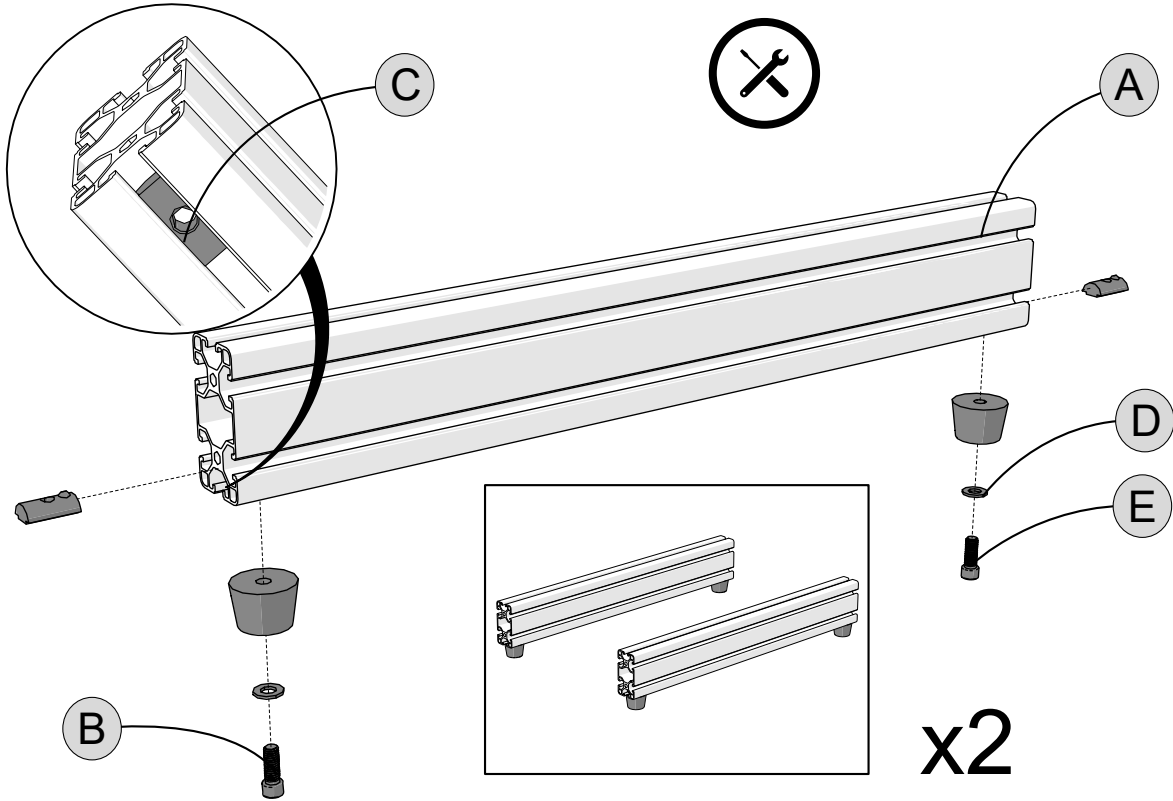
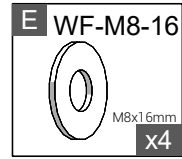
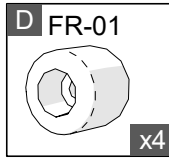
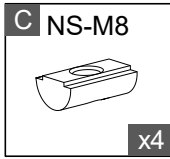
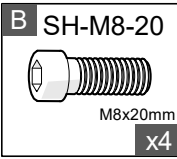
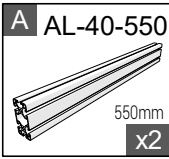

2

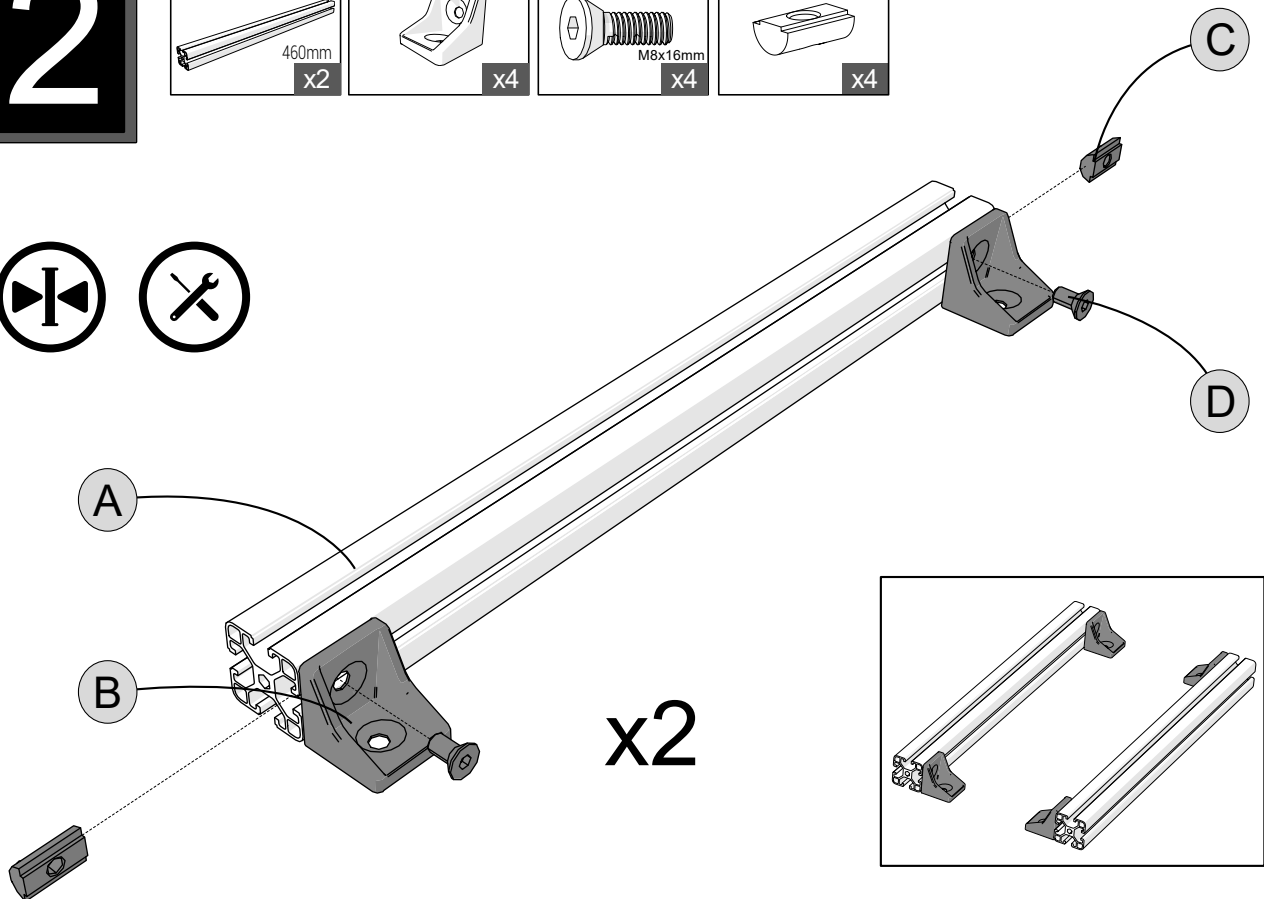
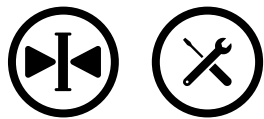
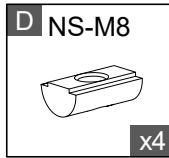
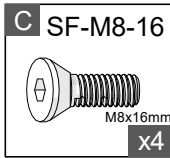
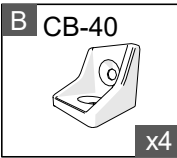

3

A TR-8040-580

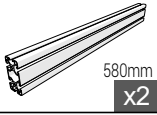

B SF-M8-16

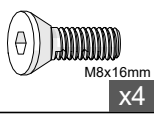

C NS-M8

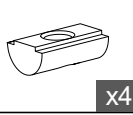

D

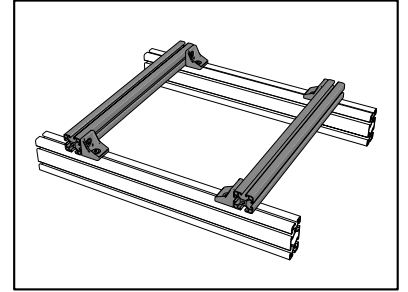
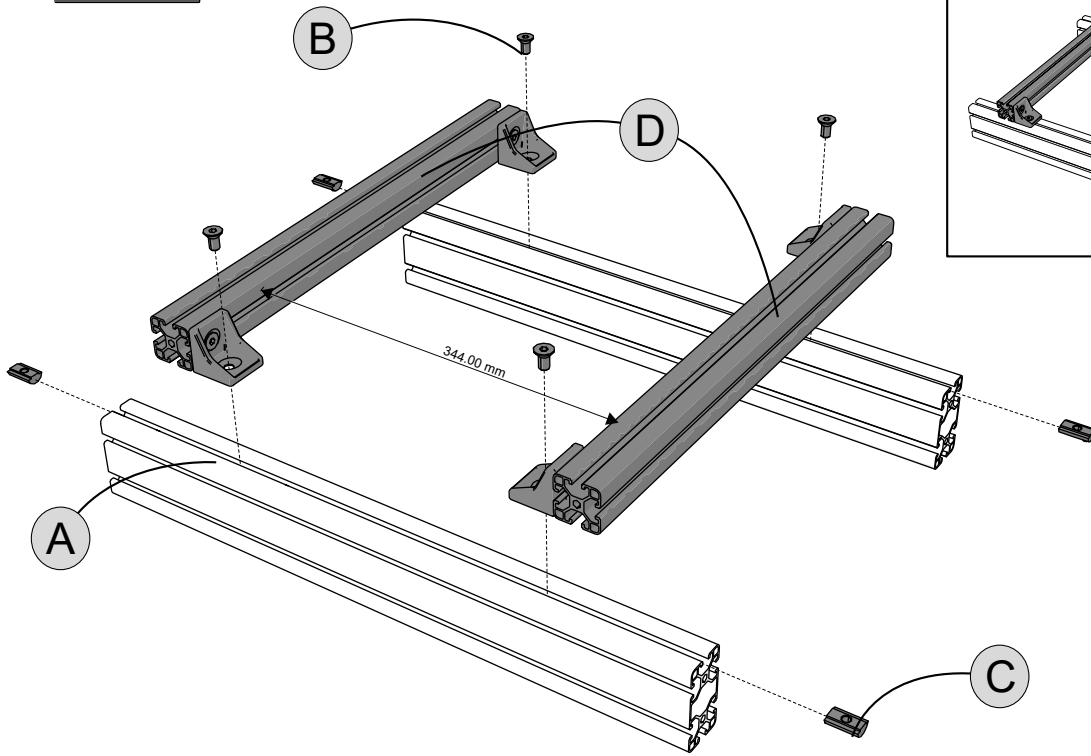
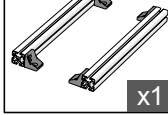

4

A

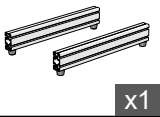

B

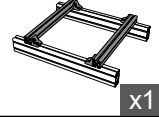

C SF-M8-16

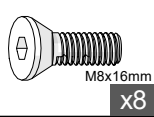

D NS-M8

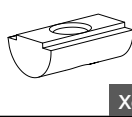

E CB-80

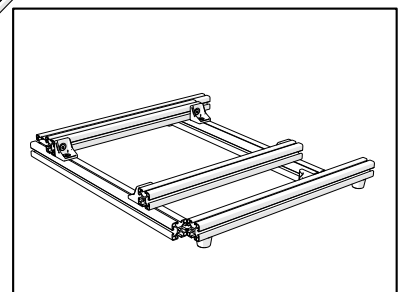
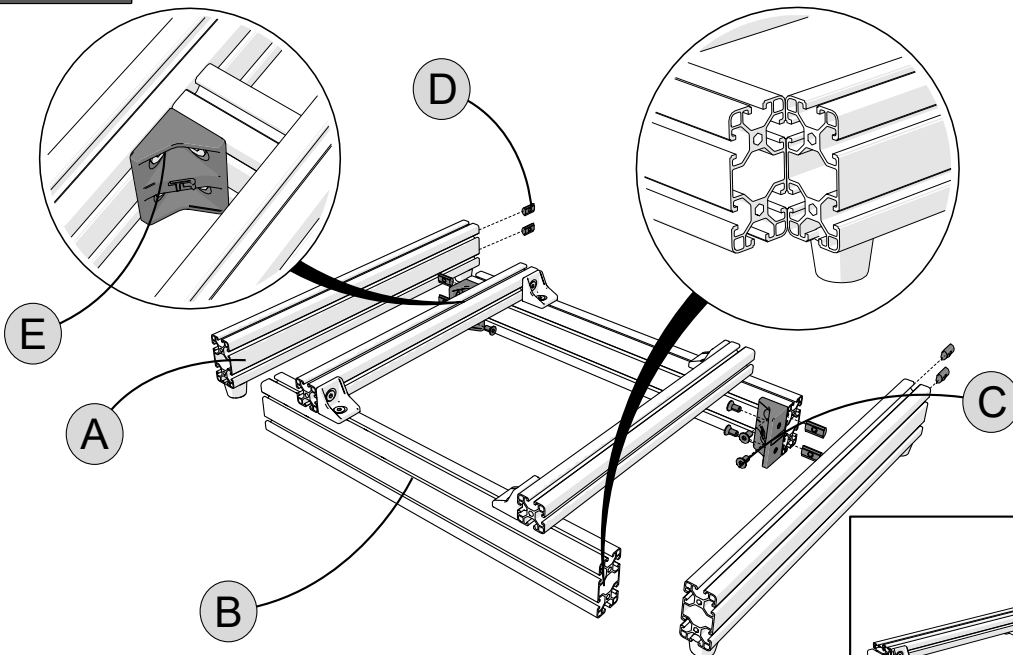

Attach parts from step 2 to step 3.

5

- A** RLP x1
- B** SH-M6-12 M6x12mm x4
- C** NS-M6 M6 x4
- D** x1

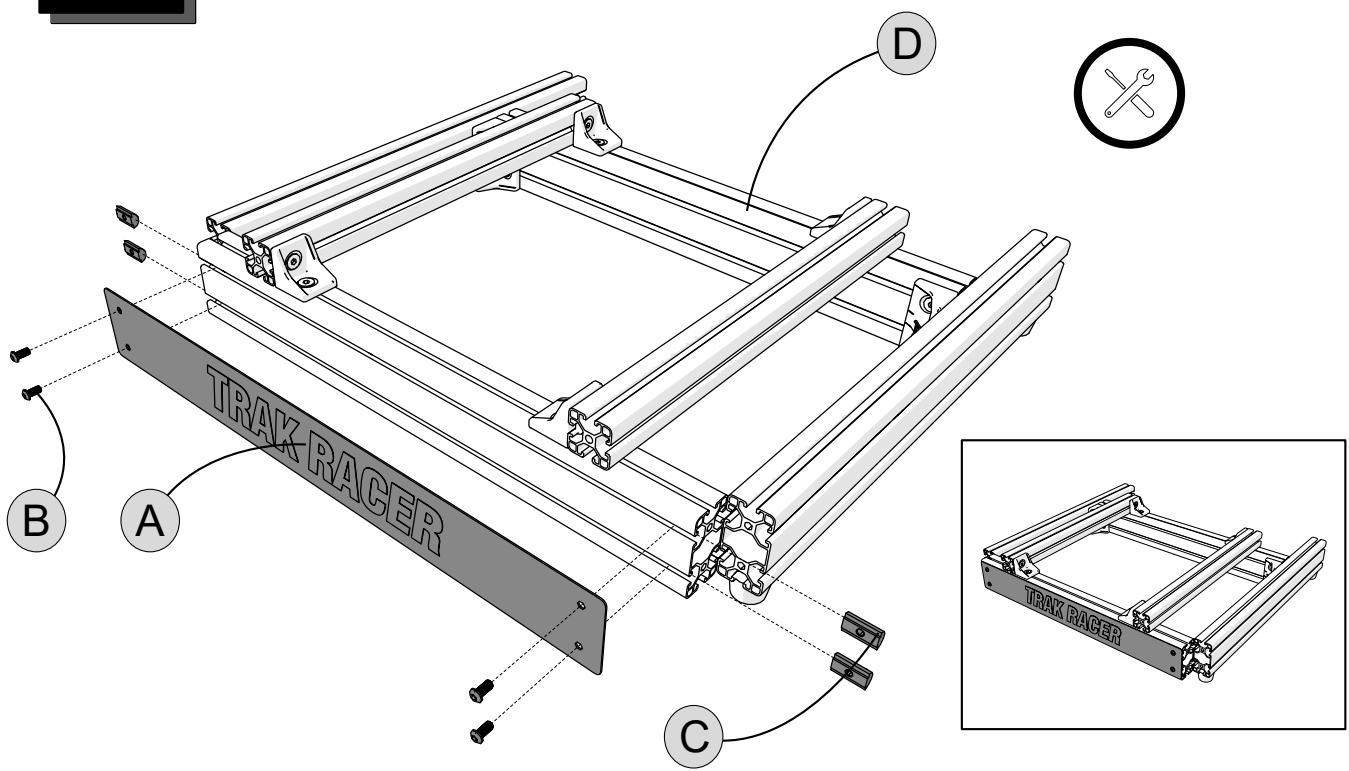



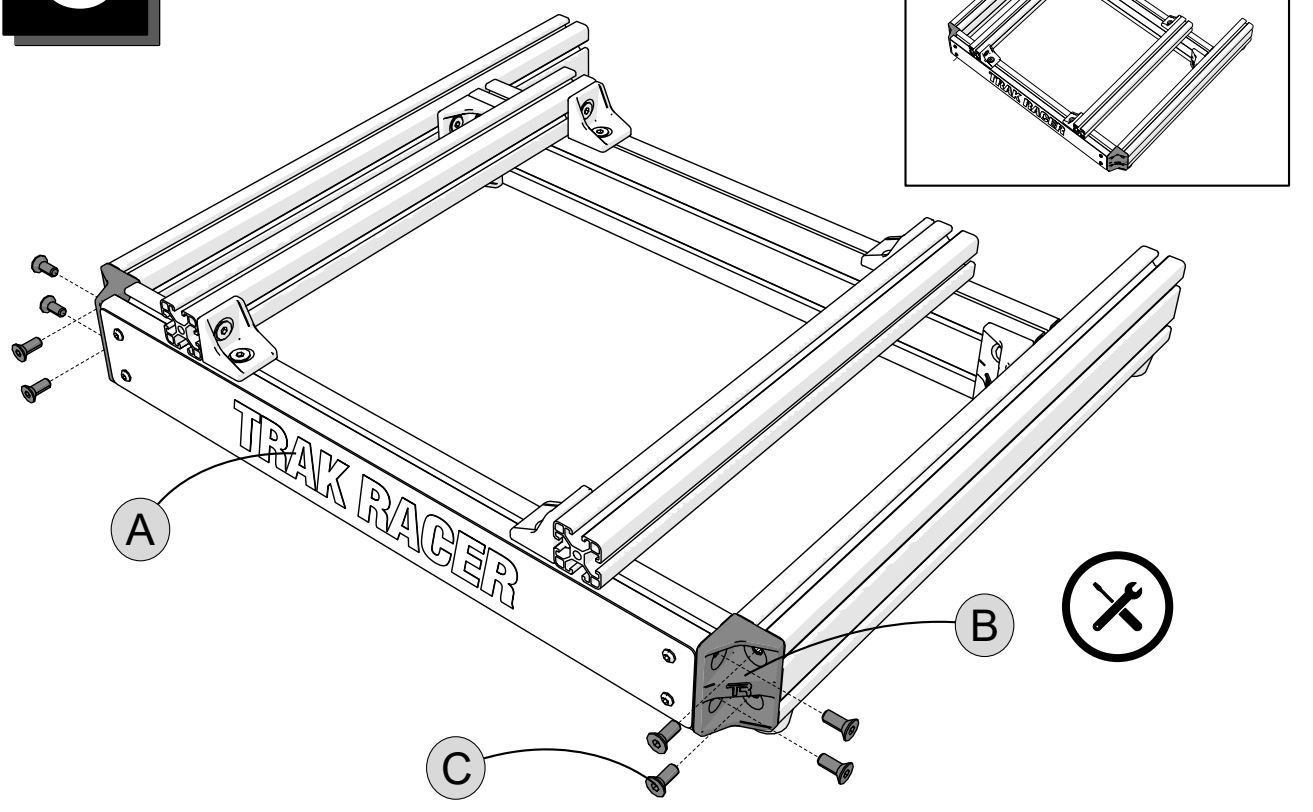

6

- A** x1
- B** CB-80 x2
- C** SF-M8-20 M8x20mm x8

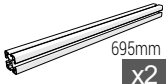
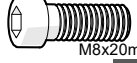

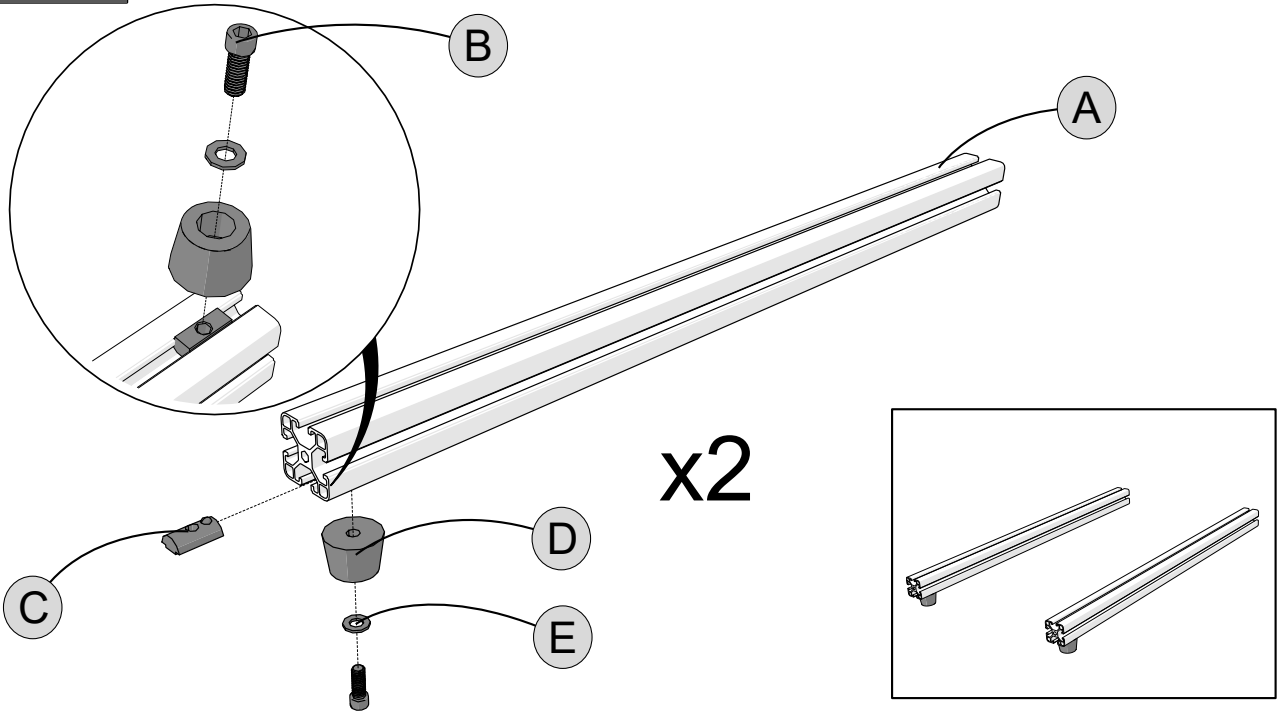

7

- | | | | | |
|--|---|---|---|---|
| A TR-8040-695  695mm x2 | B SH-M8-20  M8x20mm x2 | C NS-M8  x2 | D FR-01  x2 | E WF-M8-16  M8x16mm x2 |
|--|---|---|---|---|

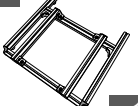
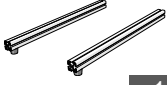
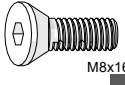
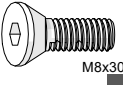

8

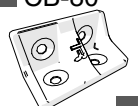
- | | | | | | |
|---|---|---|---|---|---|
| A  x1 | B  x1 | C SF-M8-16  M8x16mm x4 | D SF-M8-30  M8x30mm x4 | E NS-M8  x4 | F CB-80  x2 |
|---|---|---|---|---|---|

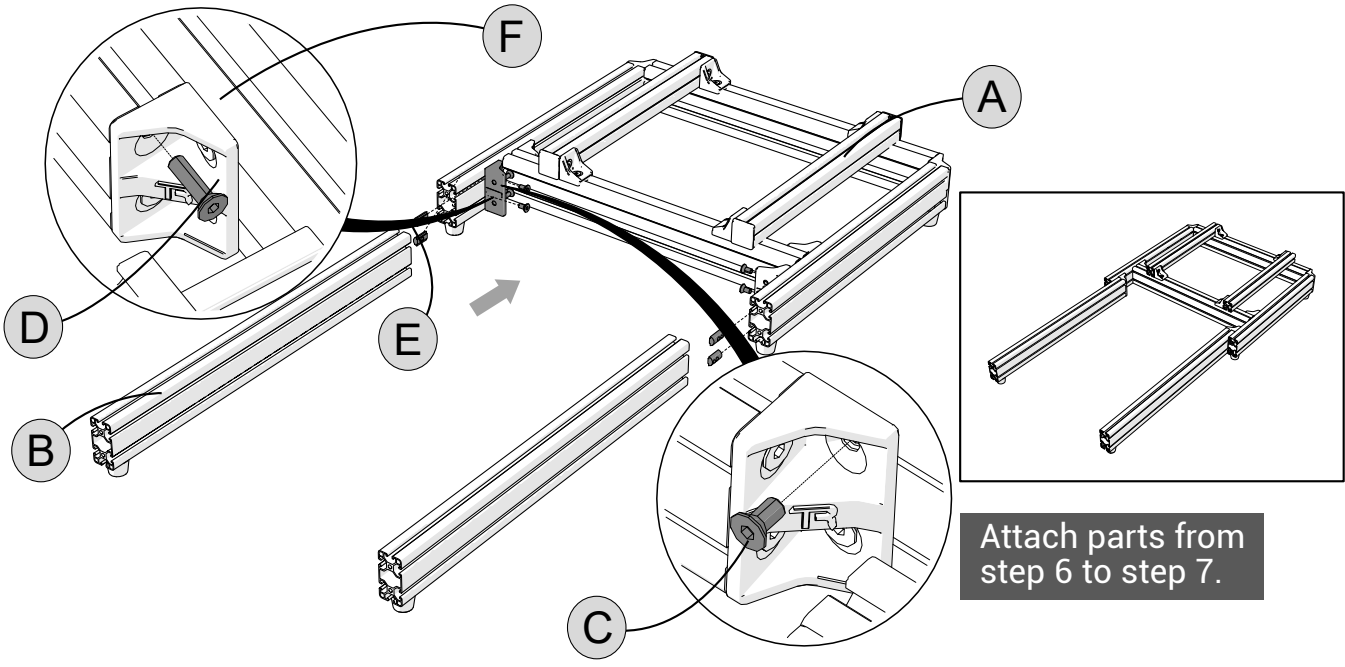

Attach parts from step 6 to step 7.

9

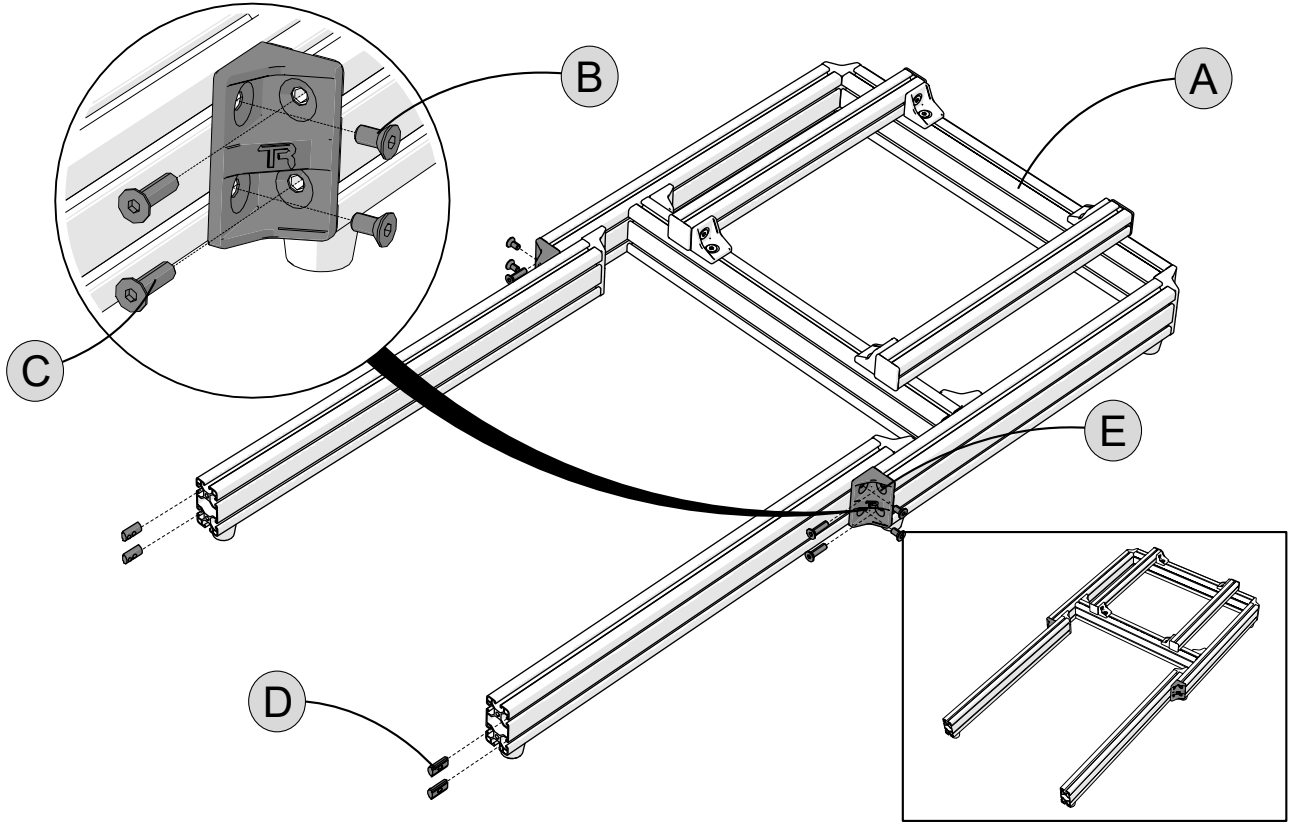
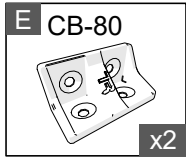
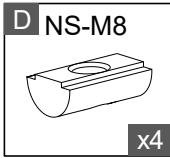
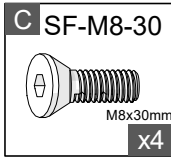
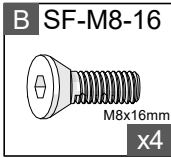
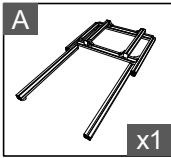

10

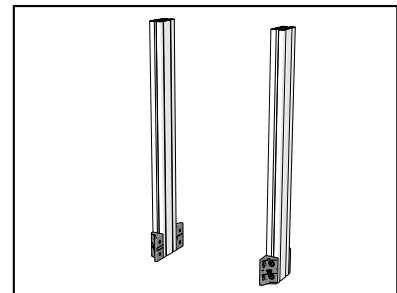
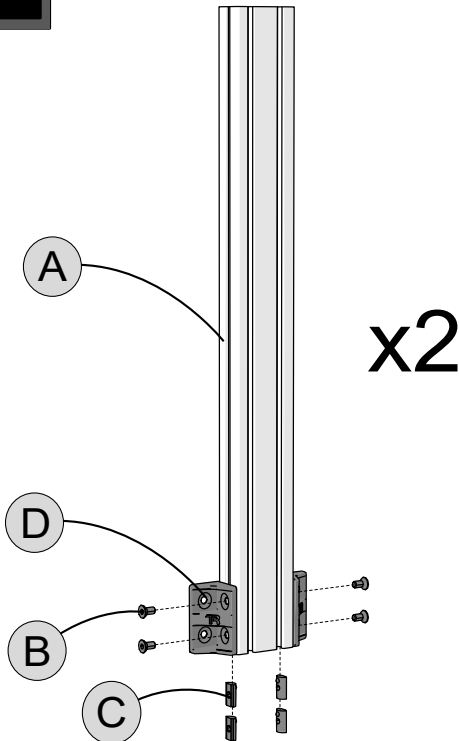
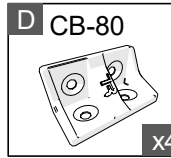
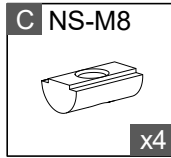
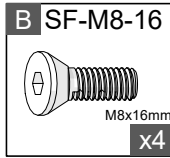
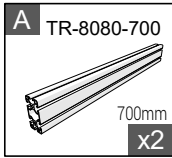

11

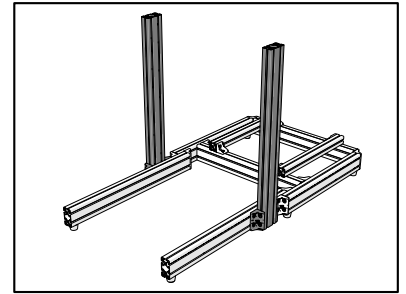
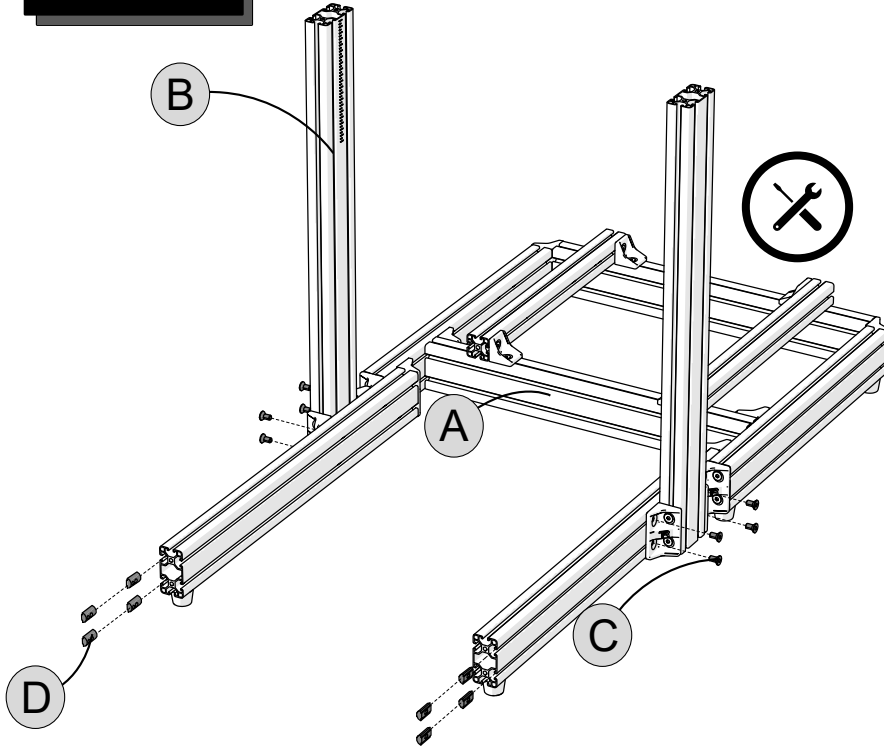
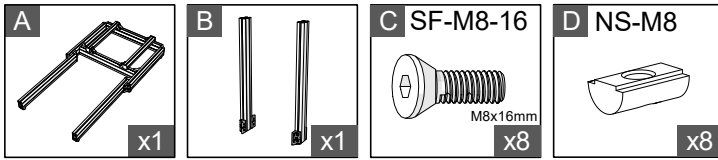

Attach parts from step 10 to step 9.

12

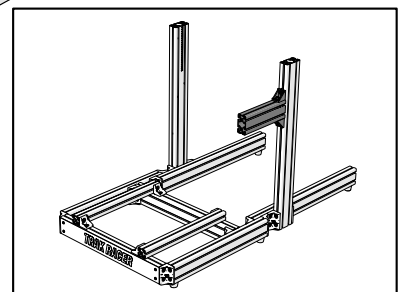
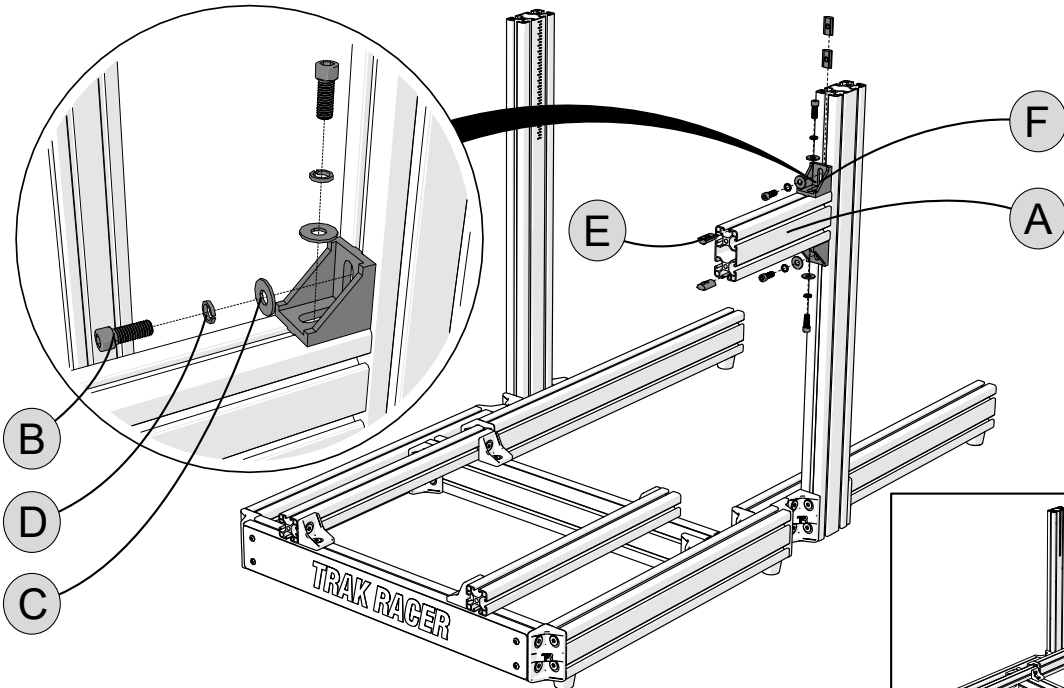
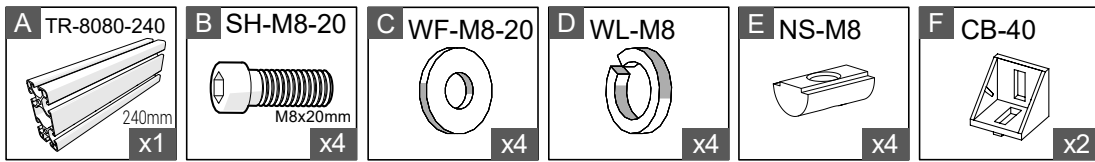

13

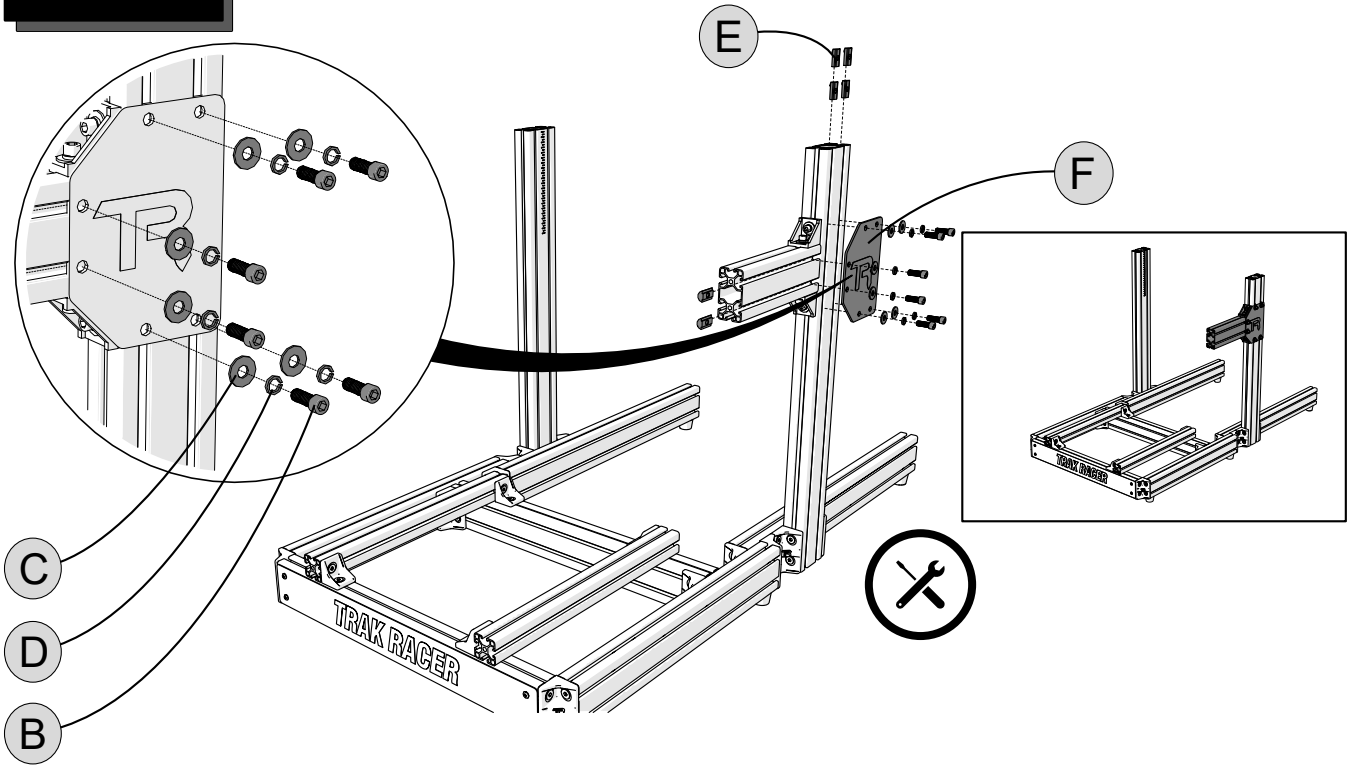
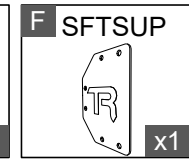
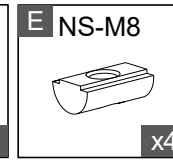
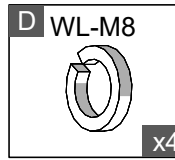
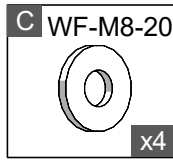
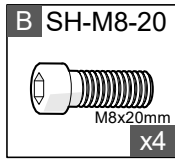
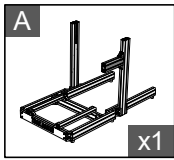

14

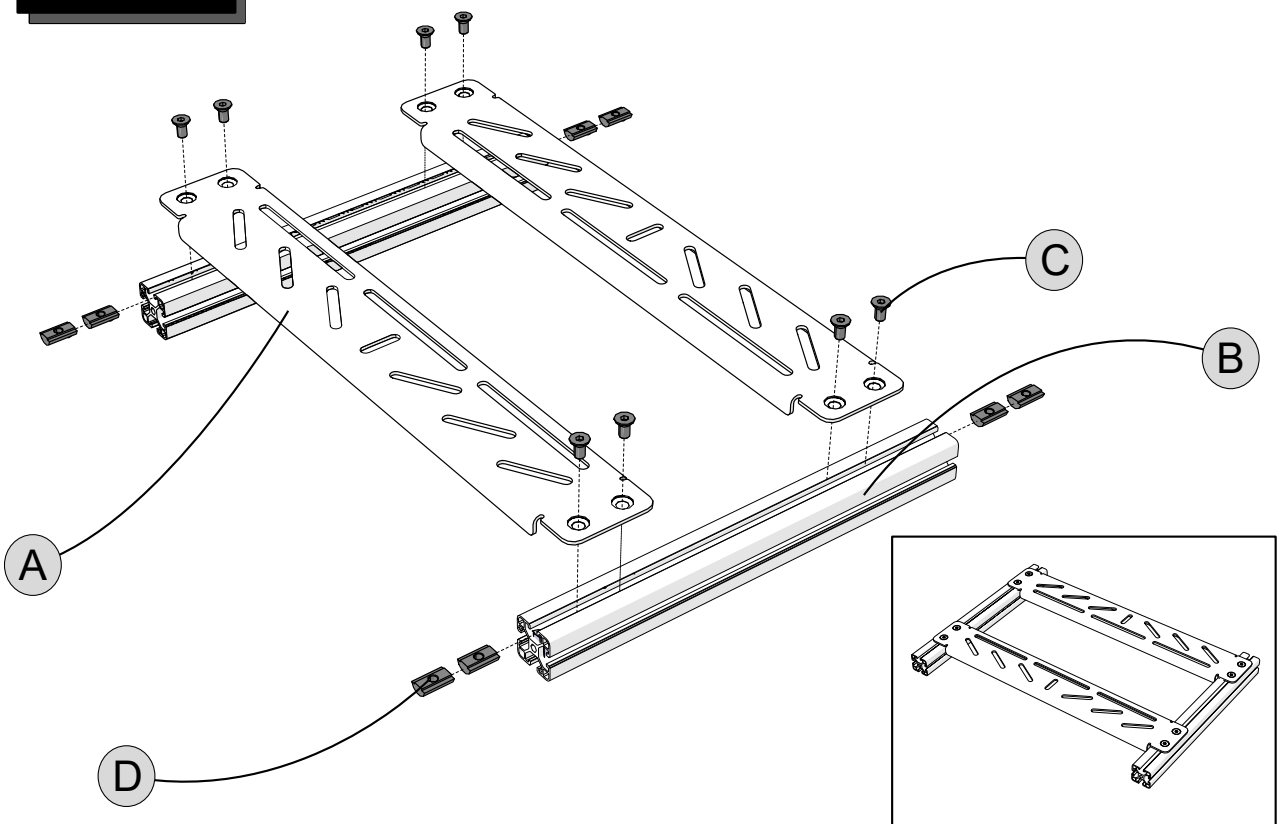
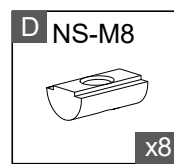
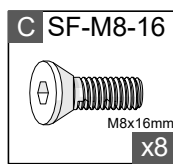
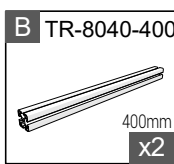
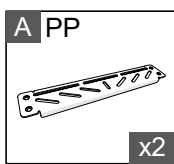



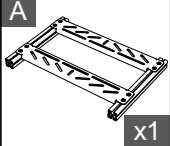
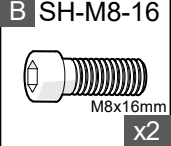
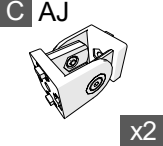

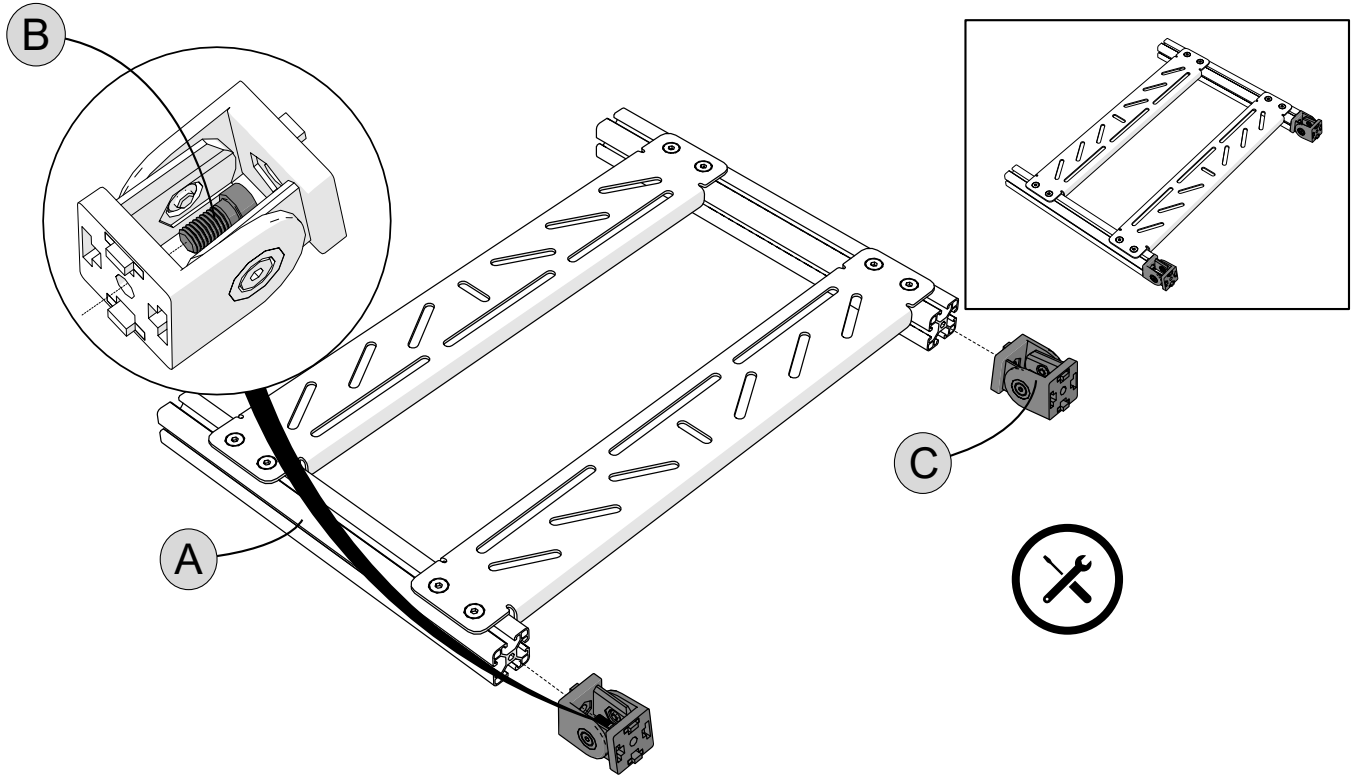
15

- A  x1
- B SH-M8-16  M8x16mm x2
- C AJ  x2

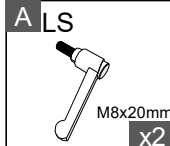

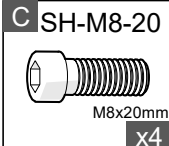
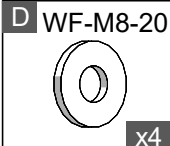

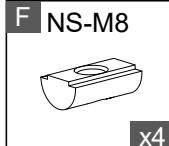
16

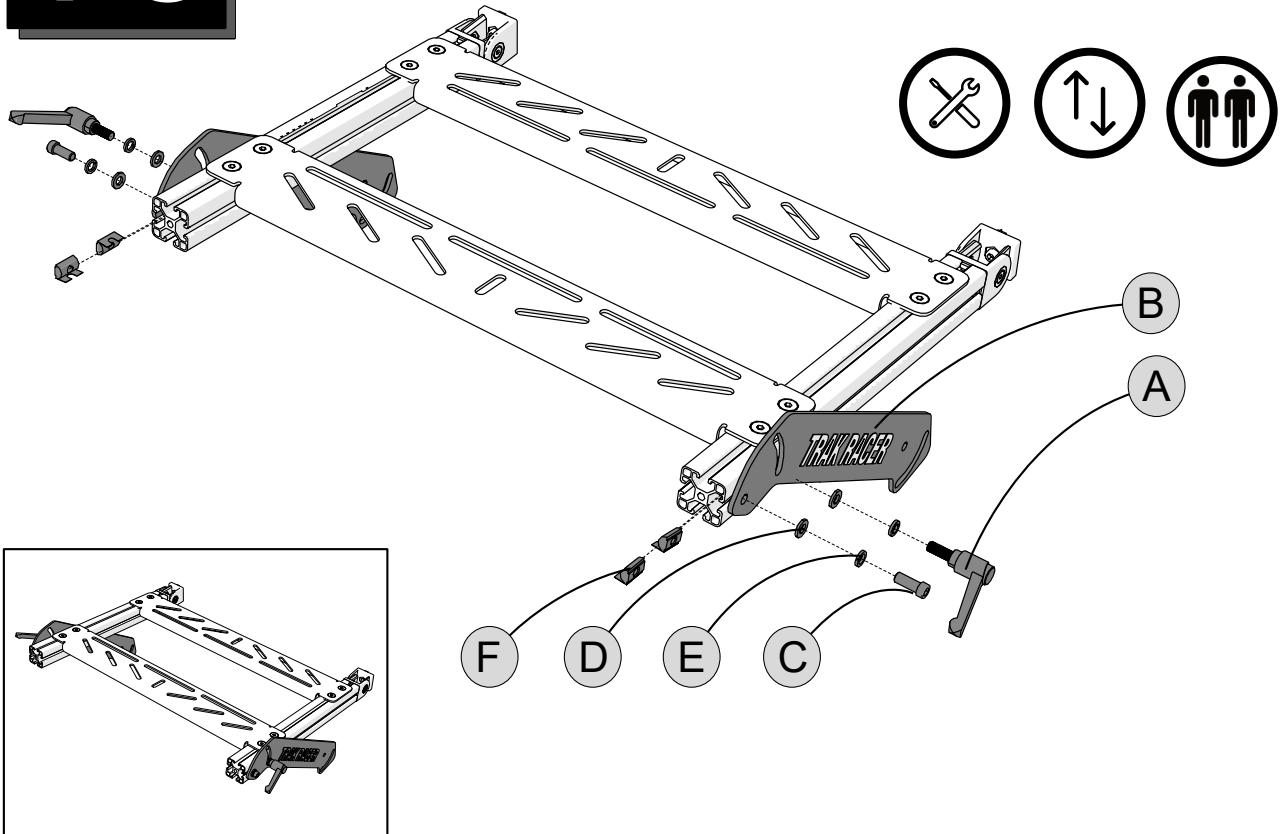
- A LS  M8x20mm x2
- B PSM  x2
- C SH-M8-20  M8x20mm x4
- D WF-M8-20  x4
- E WL-M8  x4
- F NS-M8  x4



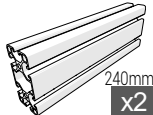
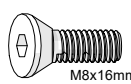
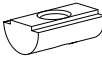

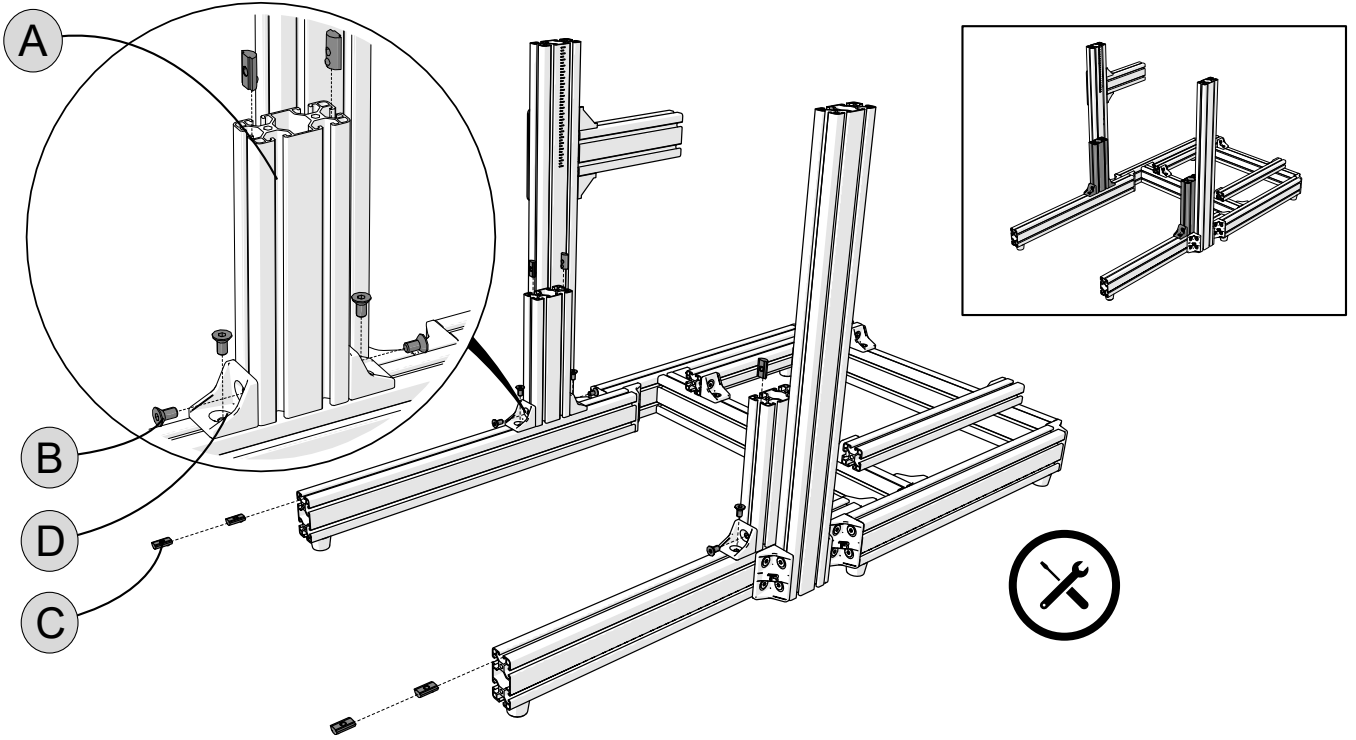

17

- A** TR-8080-240

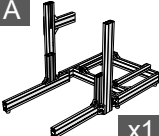
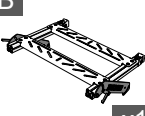
 240mm
 x2
- B** SF-M8-16

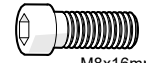
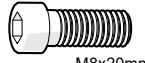
 M8x16mm
 x8
- C** NS-M8

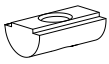
 x8
- D** CB-40

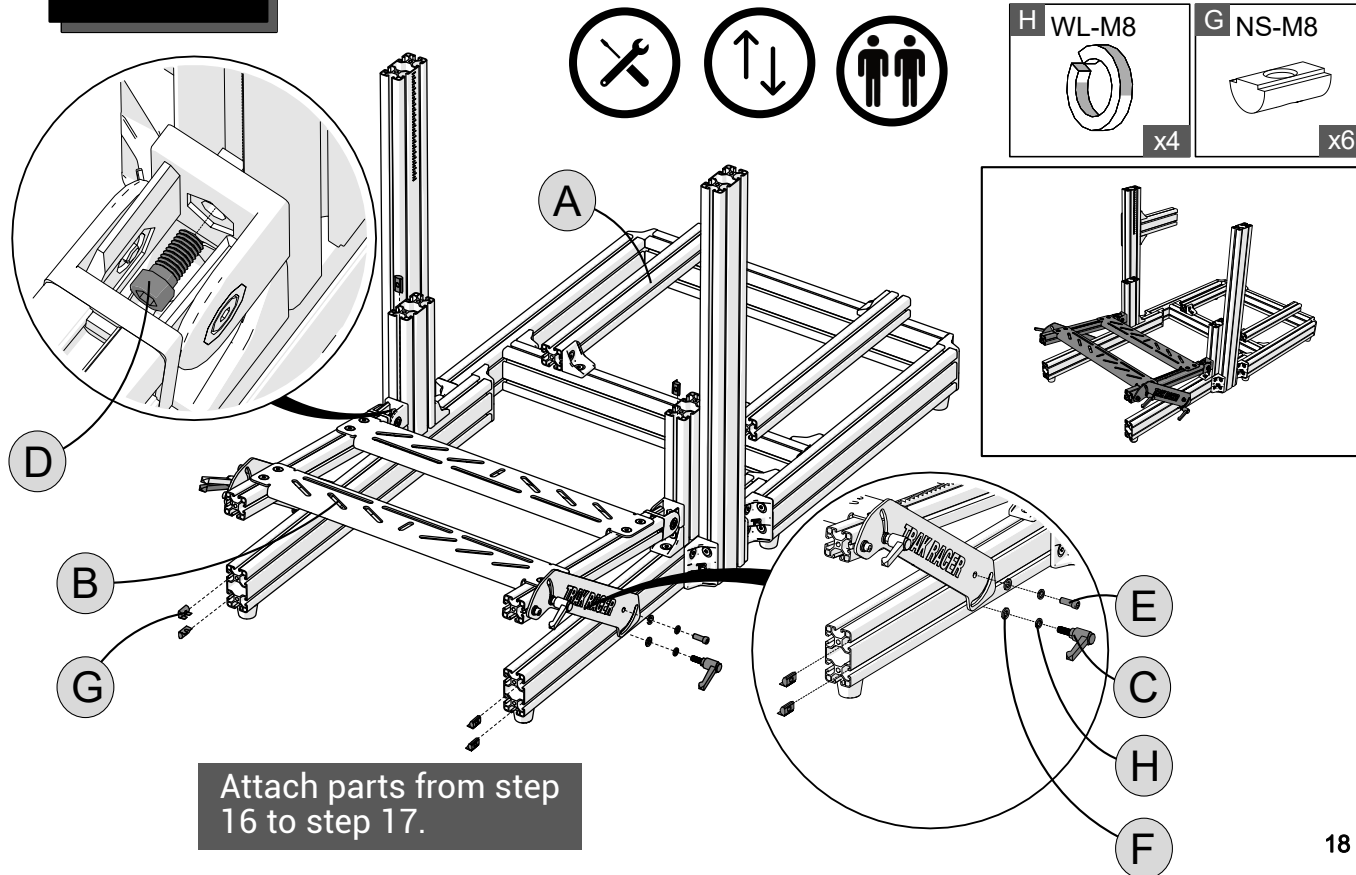
 x4



18

- A**

 x1
- B**

 x1
- C** LS

 M8x20mm
 x2
- D** SH-M8-16

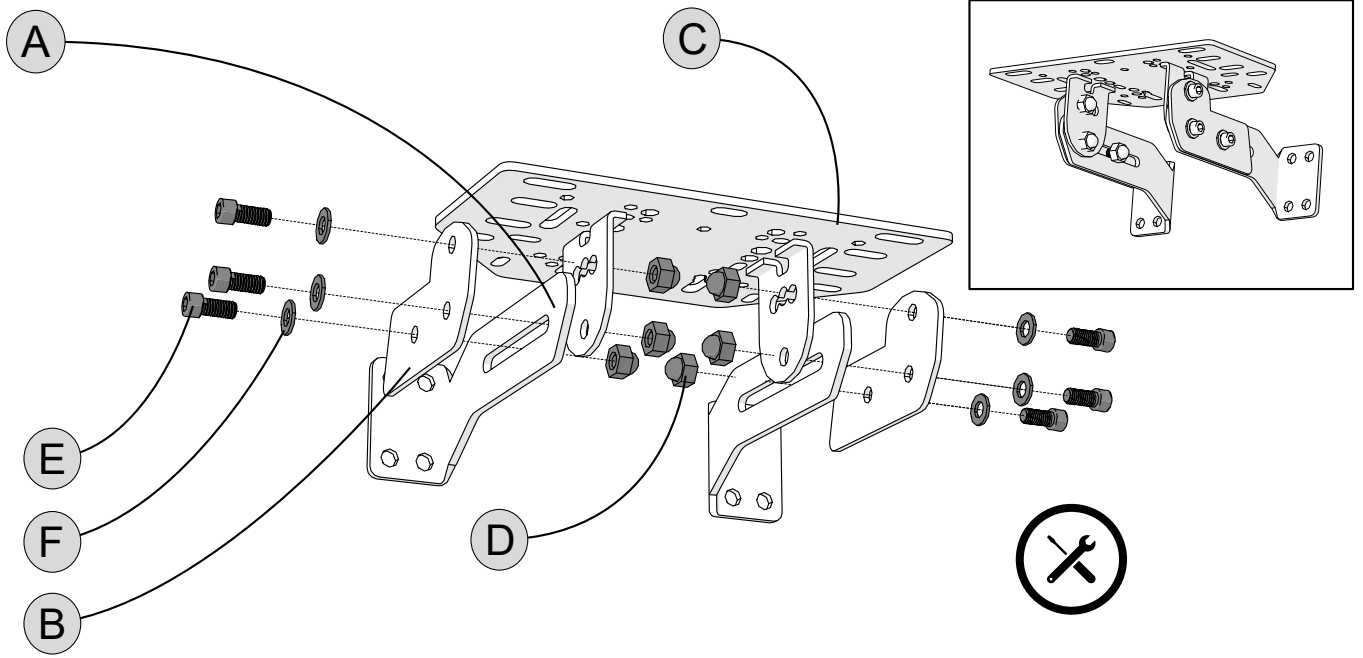
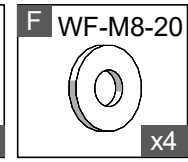
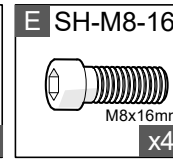
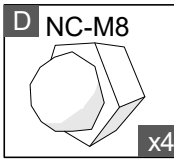
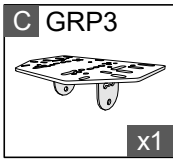
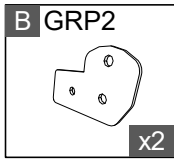
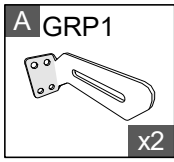
 M8x16mm
 x2
- E** SH-M8-20

 M8x20mm
 x2
- F** WF-M8-20

 x4
- H** WL-M8

 x4
- G** NS-M8

 x6



Attach parts from step 16 to step 17.

19



20

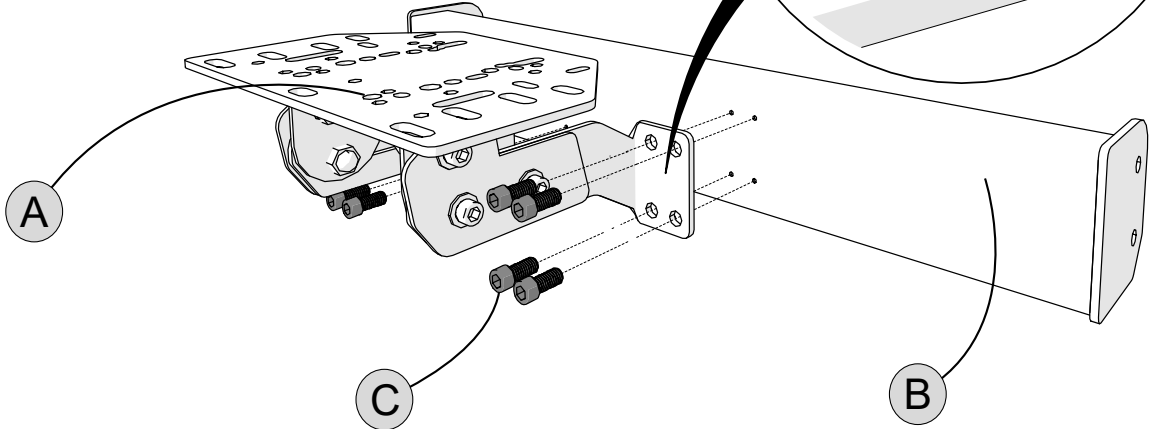
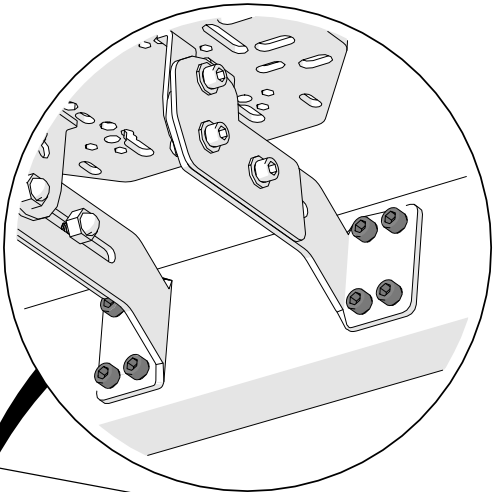
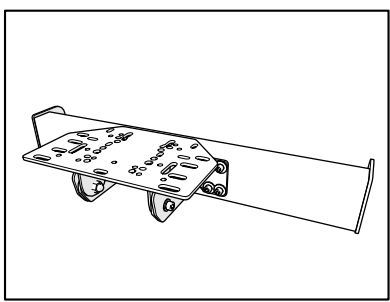
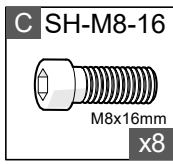
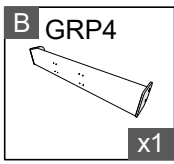
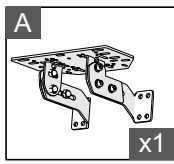

21

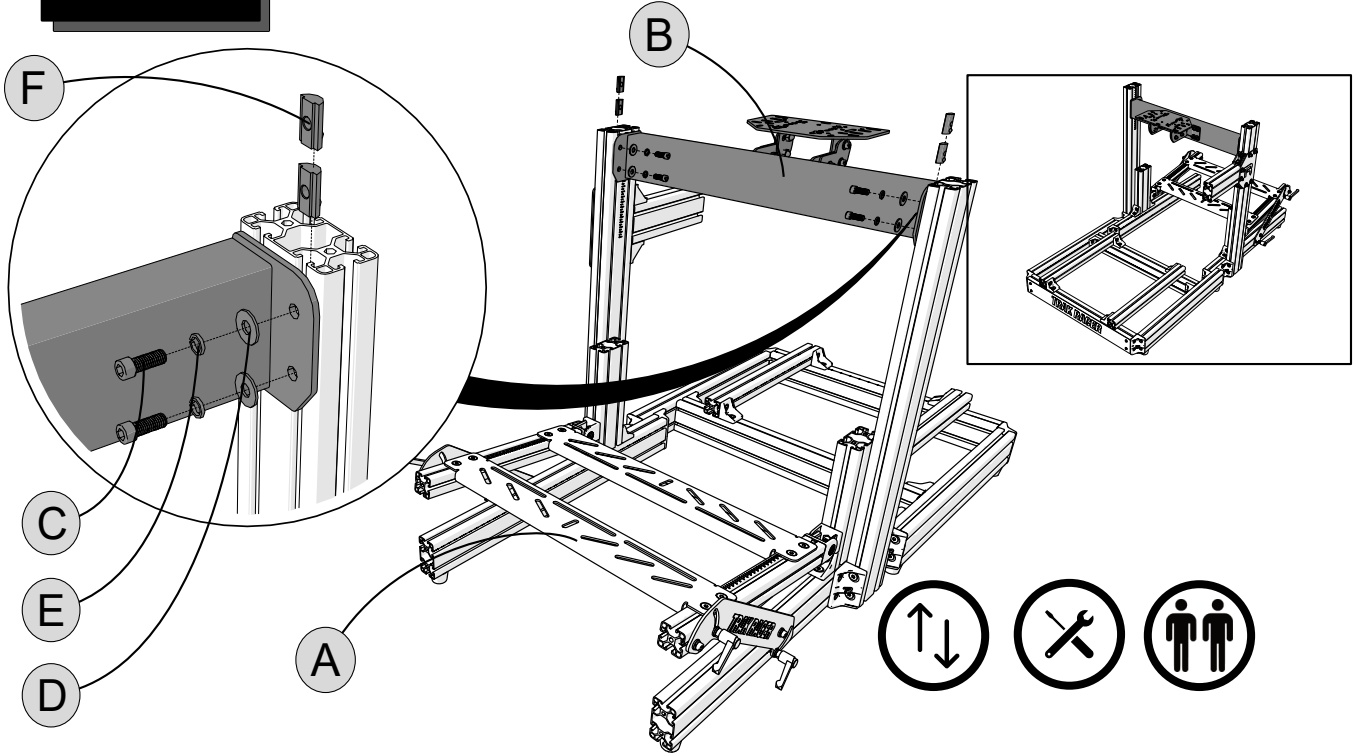
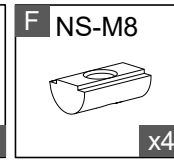
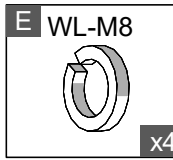
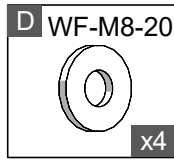
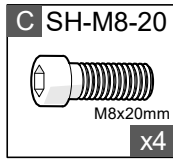
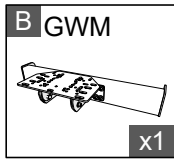
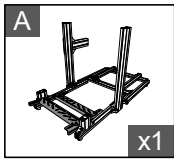

22

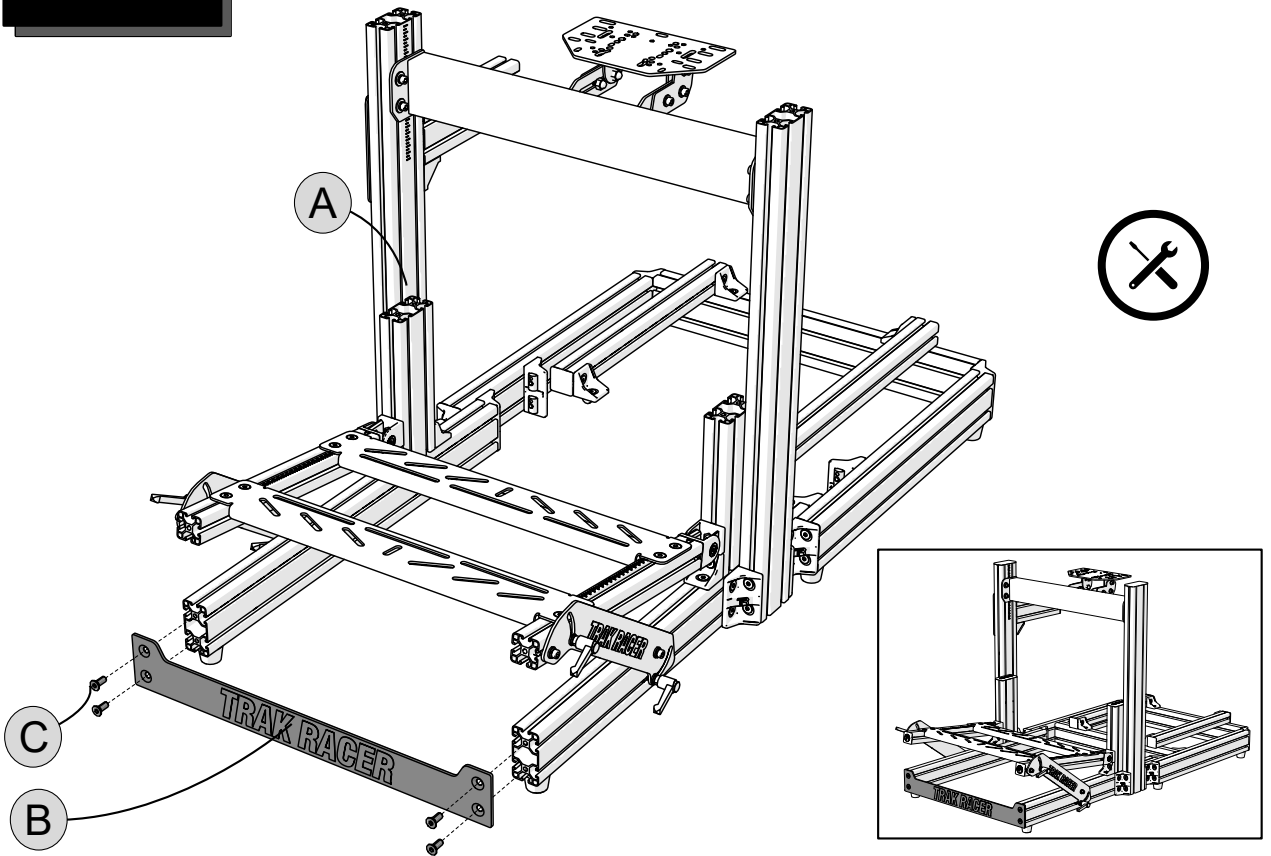
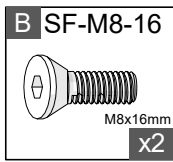
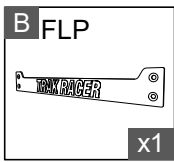
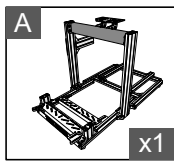

23

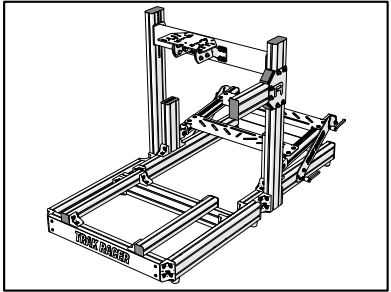
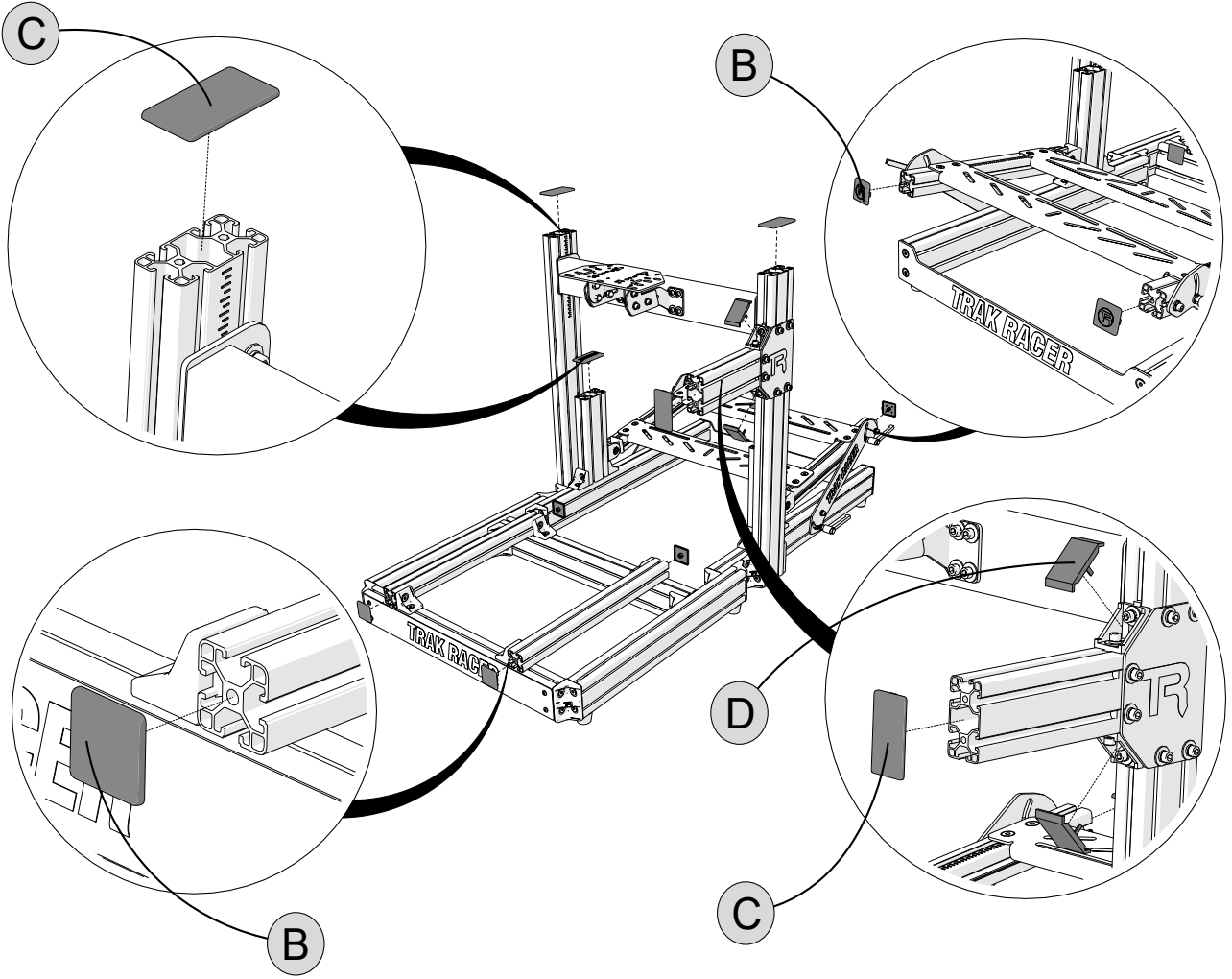
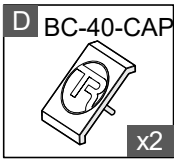
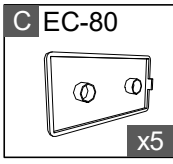
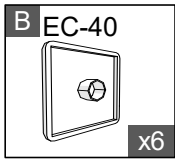
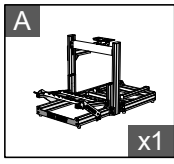

FINISHED

Share your build online and tag us to be featured!



@trakracer



@trakracer



@trak_racer