

Bosch 82mm Electronic Throttle Body - includes plug and pins

Used to electronically control the throttle and provide throttle position to the ECU. This device is used together with an Accelerator Pedal Position (APP) sensor and an ECU that supports Drive By Wire throttle control.

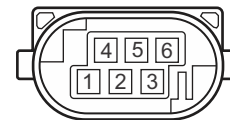
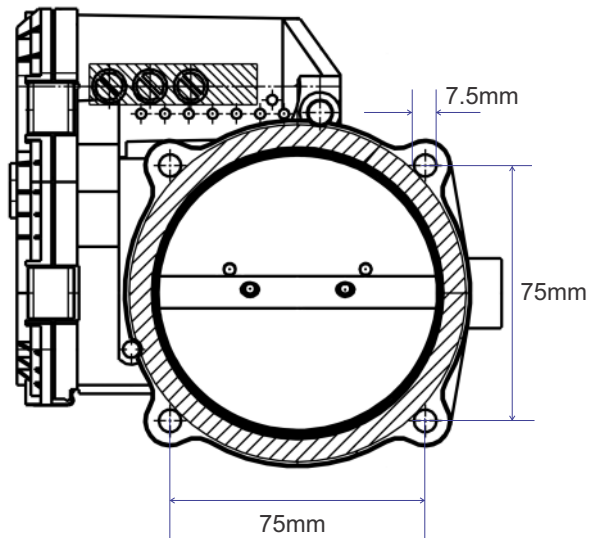

Looking into connector on electronic throttle body

Pinout and Wiring Information

Pin	Function	ECU connection
1	Motor -	DBW Motor Output or HBO
2	Signal Ground	Signal Ground
3	+5V in	+5V
4	Motor +	DBW Motor Output or HBO
5	TPS 2	Analogue Voltage Input
6	TPS 1	Analogue Voltage Input

Please take care when wiring this electronic throttle body as incorrect wiring will damage it. Refer to your ECU's wiring diagram for specific wiring information.

Haltech ECU Calibration Information

- 1.) After wiring the electronic throttle body and pedal assembly, connect the ECU to the tuning software (NSP) and go to the calibration section under Drive By Wire.
- 2.) To calibrate the pedal, click on the calibrate button with the pedal not depressed. Then click calibrate again with the pedal fully depressed.
- 3.) To calibrate the throttle, click on the calibrate button for the throttle to initiate the automatic calibration procedure.

HT-011803

Revision #1

Haltech