

NOTES:

1. THIS DRAWING DESCRIBES THE FUELAB 23903 AND 23904 SERIES FILTER ACCESSORY KIT FOR FST SYSTEMS.
2. ACCESSORY KIT IS INTENDED FOR USE WITH FUELAB FUEL SURGE TANKS PER 607xx OR 617XX SERIES ONLY.
3. FEATURES INCLUDE:
 - ALLOWS FASTER INSTALLATION BY INTEGRATING MOUNT THAT INCLUDES LOCATION FOR FILTER ASSEMBLY.
 - INCLUDES MOUNTING PLATE, 90° FITTING, CAP SCREWS, FITTED HOSE ASSEMBLY, BILLET FILTER BRACKET ASSY (PER MODEL 45102) AND BILLET FILTER (PER MODEL 81832-1)
4. SEE TABLES BELOW FOR DETERMINATION OF DESIRED MODEL NUMBER.

MODEL SELECTION TABLE

MODEL	DESCRIPTION	SERIES COMPATIBILITY, WORKS WITH:
23903	ACCESSORY KIT, 235mm TALL	MODELS 60701, 60702, 61701, 61702 OR 61703
23904	ACCESSORY KIT, 290mm TALL	MODELS 60711, 60712, 61711, 61712 OR 61713

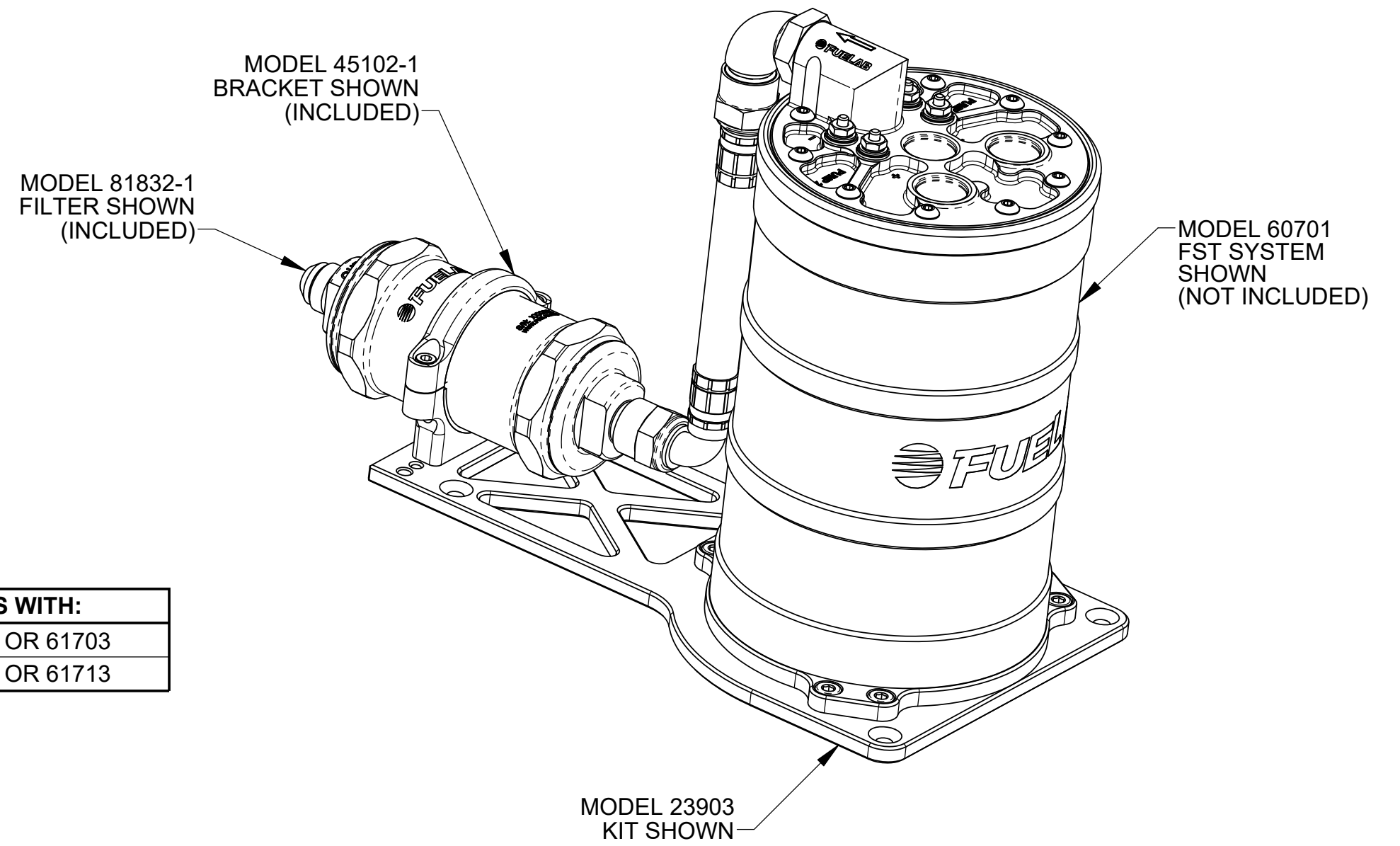

**ISOMETRIC VIEW SHOWN
(WITH MODEL 60701 SHOWN ASSEMBLED)**

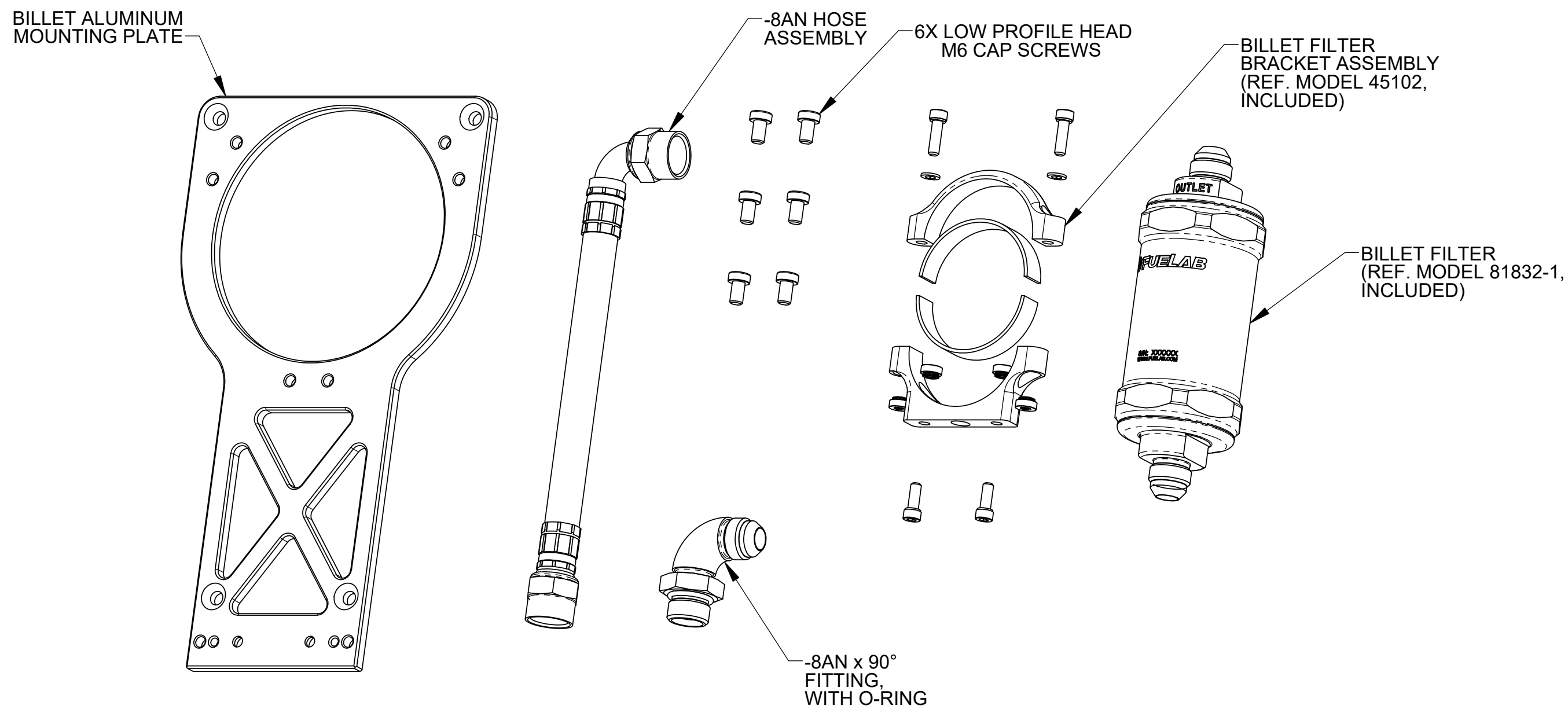

ACCESSORY KIT CONTENTS SHOWN ABOVE

UNLESS OTHERWISE SPECIFIED:		FUELAB DIGITAL FUEL DELIVERY Collinsville, Illinois	
INTERPRET DWG PER ANSI Y14.5 DIMENSIONS ARE IN INCHES		TITLE: FILTER ACCESSORY KIT, FST SYSTEMS	
TOLERANCES: FRACTIONAL: ±1/64" ANGULAR: ±1/2° DECIMALS: X±1 .XX±0.03 .XXX±0.010		SIZE C	DWG. NO. 148020200
SURFACE FINISH: 128 OR BETTER BREAK ALL SHARP EDGES: 010 MAX REMOVE ALL BURRS		SCALE: 1/2	REV B
THIRD ANGLE PROJECTION		WEIGHT:	SHEET: 1 OF 1
DO NOT SCALE DRAWING			